

# **Neousys Technology Inc.**

**POC-40 Series**

**User Manual**

Revision 1.2

# Table of Contents

<b>Table of Contents</b> .....	<b>2</b>
<b>Legal Information</b> .....	<b>4</b>
<b>Contact Information</b> .....	<b>5</b>
<b>Declaration of Conformity</b> .....	<b>5</b>
<b>Copyright Notice</b> .....	<b>6</b>
<b>Safety Precautions</b> .....	<b>7</b>
<b>Service and Maintenance</b> .....	<b>8</b>
<b>ESD Precautions</b> .....	<b>8</b>
<b>About This Manual</b> .....	<b>9</b>
<b>1 Introduction</b>	
<b>1.1 Specification of POC-40</b> .....	<b>11</b>
<b>1.2 Specification of POC-40+</b> .....	<b>13</b>
<b>1.3 Dimension</b> .....	<b>15</b>
1.3.1 Superior View .....	15
1.3.2 Front Panel View .....	16
1.3.3 Bottom View .....	17
1.3.4 Top Panel View .....	18
1.3.5 DIO Panel View .....	18
<b>2 System Overview</b>	
<b>2.1 Unpacking the System</b> .....	<b>19</b>
<b>2.2 POC-40 Series Front Panel</b> .....	<b>20</b>
2.2.1 USB 2.0 Port .....	21
2.2.2 System Status LED .....	22
2.2.3 GbE Port .....	23
2.2.4 USB 3.1 Gen1 Port .....	24
2.2.5 DisplayPort .....	25
2.2.6 Reset Button .....	26
2.2.7 4-Pin Terminal Block .....	27
<b>2.3 POC-40 Series Top Panel</b> .....	<b>28</b>
2.3.1 Power Button .....	29
2.3.2 COM2 Port (POC-40) .....	30
2.3.3 COM2 Port (POC-40+) .....	31
2.3.4 COM1 Port .....	32
2.3.5 Isolated Digital Input/ Output (POC-40+/ POC-40-DIO Only) .....	33
<b>2.4 POC-40 Series Internal I/O</b> .....	<b>35</b>
2.4.1 SO-DIMM Memory Socket .....	35
2.4.2 M.2 M Key Slot for SSD (SATA Signal Only) .....	36
2.4.3 M.2 3042/ 3052 B Key Socket (POC-40 Only) .....	38
2.4.4 Mini-PCIe Socket (POC-40+ Only) .....	40
2.4.5 M.2 E Key Socket .....	42
2.4.6 Ignition Rotary Switch (IGN Models Only) .....	44
<b>3 System Installation</b>	
<b>3.1 Disassembling the System Enclosure</b> .....	<b>46</b>
<b>3.2 Installing Internal Components</b> .....	<b>49</b>
3.2.1 DDR4 SO-DIMM Installation .....	49
3.2.2 M.2 3042/ 3052 B Key Module Installation (POC-40 Only) .....	50
3.2.3 mini-PCIe Module Installation (POC-40+ Only) .....	54
3.2.4 M Key M.2 2280 SATA SSD Module Installation .....	58
3.2.5 M.2 2230 E Key Module Installation .....	59
<b>3.3 Installing the System Enclosure</b> .....	<b>60</b>
<b>3.4 DIN Rail Installation</b> .....	<b>62</b>
<b>3.5 Powering On the System</b> .....	<b>64</b>

3.5.1	Powering On Using the Power Button.....	64
3.5.2	Powering On Using An External Non-Latched Switch.....	65
3.5.3	Powering On Using Wake-on-LAN.....	66
<b>3.6</b>	<b>Ignition Power Control (IGN Models Only) .....</b>	<b>69</b>
3.6.1	Principles of Ignition Power Control .....	69
3.6.2	Additional Features of Ignition Power Control .....	70
3.6.3	Wiring Ignition Signal .....	71
3.6.4	Configure your Windows system.....	72
3.6.5	Operation Modes of Ignition Power Control .....	73
<b>4</b>	<b>BIOS Settings</b>	
4.1	COM1 Port Configuration .....	76
4.2	COM2 Port Configuration (POC-40+ Only) .....	77
4.3	C-States .....	78
4.4	Wake-on-LAN .....	79
4.5	Power On after Power Failure.....	80
4.6	Position New Boot Device .....	81
4.7	Watchdog Timer .....	82
<b>5</b>	<b>OS Support and Driver Installation</b>	
5.1	Operating System Compatibility .....	83
5.2	Driver Installation .....	84
5.2.1	Install Drivers Automatically .....	84
5.2.2	Install Drivers Manually.....	85
5.3	Driver for Watchdog Timer and DIO.....	86
	<b>Appendix A Using WDT &amp; DIO</b>	
	<b>WDT and DIO Library Installation .....</b>	<b>88</b>
	<b>WDT Function Reference.....</b>	<b>90</b>
	InitWDT .....	90
	SetWDT .....	90
	StartWDT.....	91
	ResetWDT.....	91
	StopWDT.....	91

# Legal Information

All Neosys Technology Inc. products shall be subject to the latest Standard Warranty Policy

Neosys Technology Inc. may modify, update or upgrade the software, firmware or any accompanying user documentation without any prior notice. Neosys Technology Inc. will provide access to these new software, firmware or documentation releases from download sections of our website or through our service partners.

Before installing any software, applications or components provided by a third party, customer should ensure that they are compatible and interoperable with Neosys Technology Inc. product by checking in advance with Neosys Technology Inc. Customer is solely responsible for ensuring the compatibility and interoperability of the third party's products. Customer is further solely responsible for ensuring its systems, software, and data are adequately backed up as a precaution against possible failures, alternation, or loss.

For questions in regards to hardware/ software compatibility, customers should contact Neosys Technology Inc. sales representative or technical support.

To the extent permitted by applicable laws, Neosys Technology Inc. shall NOT be responsible for any interoperability or compatibility issues that may arise when (1) products, software, or options not certified and supported; (2) configurations not certified and supported are used; (3) parts intended for one system is installed in another system of different make or model.

# Contact Information

---

**Headquarters**  
**(Taipei, Taiwan)**

**Neosys Technology Inc.**  
15F, No.868-3, Zhongzheng Rd., Zhonghe Dist., New Taipei City, 23586, Taiwan  
Tel: +886-2-2223-6182 Fax: +886-2-2223-6183 [Email](#), [Website](#)

---

**Americas**  
**(Illinois, USA)**

**Neosys Technology America Inc.**  
3384 Commercial Avenue, Northbrook, IL 60062, USA  
Tel: +1-847-656-3298 [Email](#), [Website](#)

---

**China**

**Neosys Technology (China) Ltd.**  
Room 612, Building 32, Guiping Road 680, Shanghai  
Tel: +86-2161155366 [Email](#), [Website](#)

---

# Declaration of Conformity

**FCC**

This equipment has been tested and found to comply with the limits for a Class A digital device, pursuant to part 15 of the FCC Rules. These limits are designed to provide reasonable protection against harmful interference when the equipment is operated in a commercial environment. This equipment generates, uses, and can radiate radio frequency energy and, if not installed and used in accordance with the instruction manual, may cause harmful interference to radio communications. Operation of this equipment in a residential area is likely to cause harmful interference in which case the user will be required to correct the interference at own expense.

---

**CE**

The product(s) described in this manual complies with all applicable European Union (CE) directives if it has a CE marking. For computer systems to remain CE compliant, only CE-compliant parts may be used. Maintaining CE compliance also requires proper cable and cabling techniques.

# Copyright Notice

All rights reserved. This publication may not be reproduced, transmitted, transcribed, stored in a retrieval system, or translated into any language or computer language, in any form or by any means, electronic, mechanical, magnetic, optical, chemical, manual or otherwise, without the prior written consent of Neosys Technology, Inc.

---

## **Disclaimer**

This manual is intended to be used as an informative guide only and is subject to change without prior notice. It does not represent commitment from Neosys Technology Inc. Neosys Technology Inc. shall not be liable for any direct, indirect, special, incidental, or consequential damages arising from the use of the product or documentation, nor for any infringement on third party rights.

---

## **Patents and Trademarks**

Neosys, the Neosys logo, Expansion Cassette, MezIO™ are registered patents and trademarks of Neosys Technology, Inc.

Windows is a registered trademark of Microsoft Corporation.

Intel®, Core™ are registered trademarks of Intel Corporation

NVIDIA®, GeForce® are registered trademarks of NVIDIA Corporation

All other names, brands, products or services are trademarks or registered trademarks of their respective owners.

# Safety Precautions

- Read these instructions carefully before you install, operate, or transport the system.
- Install the system or DIN rail associated with, at a sturdy location
- Install the power socket outlet near the system where it is easily accessible
- Secure each system module(s) using its retaining screws
- Place power cords and other connection cables away from foot traffic. Do not place items over power cords and make sure they do not rest against data cables
- Shutdown, disconnect all cables from the system and ground yourself before touching internal modules
- Ensure that the correct power range is being used before powering the device
- Should a module fail, arrange for a replacement as soon as possible to minimize down-time
- If the system is not going to be used for a long time, disconnect it from mains (power socket) to avoid transient over-voltage

# Service and Maintenance

- ONLY qualified personnel should service the system
- Shutdown the system, disconnect the power cord and all other connections before servicing the system
- When replacing/ installing additional components (expansion card, memory module, etc.), insert them as gently as possible while assuring proper connector engagement

# ESD Precautions

- Handle add-on module, motherboard by their retention screws or the module's frame/ heat sink. Avoid touching the PCB circuit board or add-on module connector pins
- Use a grounded wrist strap and an anti-static work pad to discharge static electricity when installing or maintaining the system
- Avoid dust, debris, carpets, plastic, vinyl and styrofoam in your work area.
- Do not remove any module or component from its anti-static bag before installation



# About This Manual

This manual introduces and demonstrates installation procedures of Neosys POC-40 series systems. An extremely compact fanless computer featuring Intel® Elkhart Lake Atom®, it is designed for space-restricted deployments such as factory data collection, rugged edge computing, and mobile gateway applications.

## Revision History

Version	Date	Description
1.0	Dec. 2022	Initial release
1.1	Apr. 2023	Updated specifications
1.2	Sep. 2023	Added POC-40+ series systems

# 1 Introduction

POC-40/ POC-40+ is an extremely compact fanless controller with dimensions measuring just 52 x 89 x 112 mm. It features Elkhart Lake Atom® processor that is designed for space-restricted industrial applications such as edge computing or data collection.

The new Intel® Elkhart lake Atom® x6413E quad-core/ x6211E dual-core processor utilizes 10 nm process technology, which delivers up to 1.8x the performance of its previous generation. In comparison to POC-200, POC-40 provides nearly 1.9x the computing performance at only 1/2 the size. Built for industrial applications, it features rich I/O ports such as two Gigabit Ethernet LAN ports, four USB 3.1 Gen1/ 2.0 ports and integrated 4-ch isolated digital inputs/ outputs so you can connect general sensors or cameras for machine vision purposes. POC-40 also has up to four COM ports for generic device communication. Wireless connectivity is essential for the modern mobile gateway, and POC-40 provides M.2 E key for full bandwidth WiFi 5/ WiFi 6 and B key for 4G/ 5G module facilitating long-distance data transmission and allowing real-time communication.



With a similar form factor as a traditional PICO-ITX, Neosys' POC-40 is perfect for projects that require above par performance in an extremely compact package. POC-40 is a low power consumption, lightweight fanless design system that offers wide temperature operation capability to suit harsh outdoor environments. It is the ideal platform for outdoors as a mobile or industrial gateway.

## 1.1 Specification of POC-40

<b>System Core</b>	
Processor	Intel® Elkhart Lake Atom® x6211E dual-core 1.2GHz/ 3.0GHz 6W processor
Graphics	Integrated Intel® UHD Graphics
Memory	Up to 32 GB DDR4-3200 SDRAM by one SODIMM socket
<b>Panel I/O Interface</b>	
Ethernet	2x Gigabit Ethernet ports by Intel® I210 GbE controllers
USB	2x USB 3.1 Gen1 (5 Gbps) ports 2x USB 2.0 ports
Video Port	1x DisplayPort connector, supporting 4096 x 2160 resolution @ 60Hz
Serial Port	1x software-programmable RS-232/422/485 ports (COM1) 1x 3-wire RS-232 ports (COM2)
Isolated Digital I/O (optional)	Optional 4-ch isolated digital input and 4-ch isolated digital output
<b>Storage Interface</b>	
M.2 M key	1x M.2 2280 M key SATA interface
<b>Internal Expansion Bus</b>	
M.2 B key	1x M.2 3042/ 3052 B key socket with internal SIM card socket for 4G/ 5G module
M.2 E key	1x M.2 2230 E key socket for WiFi 5/ WiFi 6
<b>Power Supply</b>	
DC Input	1x 4-pin pluggable terminal block for 12-20V DC input with optional ignition power control (POC-40-IGN only)
Remote Ctrl	1x 4-pin pluggable terminal block for remote control
<b>Mechanical</b>	
Dimension	52 mm (W) x 89 mm (D) x 112 mm (H)
Weight	0.6kg
Mounting	DIN-rail mount (standard) or Wall-mount (optional)
<b>Environmental</b>	
Operating Temperature	-25°C ~ 70°C **/
Storage Temperature	-40°C ~85°C **/

Humidity	10%~90% , non-condensing
Vibration	Operating, MIL-STD-810G, Method 514.6, Category 4
Shock	Operating, MIL-STD-810G, Method 516.6, Procedure I, Table 516.6-II
EMC	CE/FCC Class A, according to EN 55032 & EN 55035

*\* The 100% CPU/GPU loading for high temperature test is applied using Passmark® BurnInTest™ v8.0. For detail testing criteria, please contact Neosys Technology*

*\*\* For sub-zero operating temperature, a wide temperature HDD drive or Solid State Disk (SSD) is required.*

## 1.2 Specification of POC-40+

<b>System Core</b>	
Processor	Intel® Elkhart Lake Atom® x6413E quad-core 1.5GHz/ 3.0GHz 9W processor
Graphics	Integrated Intel® UHD Graphics
Memory	Up to 32 GB DDR4-3200 SDRAM by one SODIMM socket
<b>Panel I/O Interface</b>	
Ethernet	2x Gigabit Ethernet ports by Intel® I210 GbE controllers
USB	2x USB 3.1 Gen1 (5 Gbps) ports 2x USB 2.0 ports
Video Port	1x DisplayPort connector, supporting 4096 x 2160 resolution @ 60Hz
Serial Port	1x software-programmable RS-232/422/485 ports (COM1) 1x 3-wire RS-232 ports (COM2)
Isolated Digital I/O	4-ch isolated digital input and 4-ch isolated digital output
<b>Storage Interface</b>	
M.2 M key	1x M.2 2280 M key SATA interface
<b>Internal Expansion Bus</b>	
M.2 E key	1x M.2 2230 E key socket for WiFi 5/ WiFi 6
mini-PCIe	1x full-size mini-PCIe Express slot with internal SIM socket
<b>Power Supply</b>	
DC Input	1x 4-pin pluggable terminal block for 12-20V DC input with optional ignition power control (POC-40+IGN only)
Remote Ctrl	1x 4-pin pluggable terminal block for remote control
<b>Mechanical</b>	
Dimension	52 mm (W) x 89 mm (D) x 112 mm (H)
Weight	0.6kg
Mounting	DIN-rail mount (standard) or Wall-mount (optional)
<b>Environmental</b>	
Operating Temperature	-25°C ~ 70°C */**
Storage Temperature	-40°C ~85°C */**
Humidity	10%~90% , non-condensing

Vibration	Operating, MIL-STD-810G, Method 514.6, Category 4
Shock	Operating, MIL-STD-810G, Method 516.6, Procedure I, Table 516.6-II
EMC	CE/FCC Class A, according to EN 55032 & EN 55035

*\* The 100% CPU/GPU loading for high temperature test is applied using Passmark® BurnInTest™ v8.0. For detail testing criteria, please contact Neosys Technology*

**\*\* For sub-zero operating temperature, a wide temperature HDD drive or Solid State Disk (SSD) is required.**

### 1.3 Dimension



**NOTE**

*The POC-40 series systems share the same dimensions.*

#### 1.3.1 Superior View

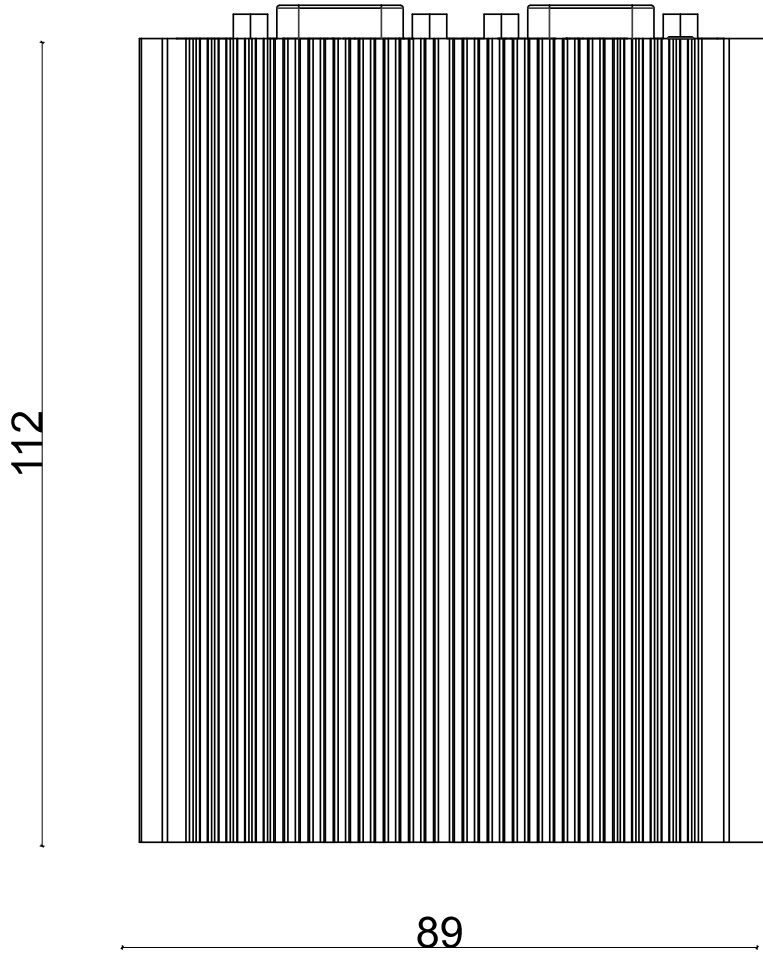

### 1.3.2 Front Panel View

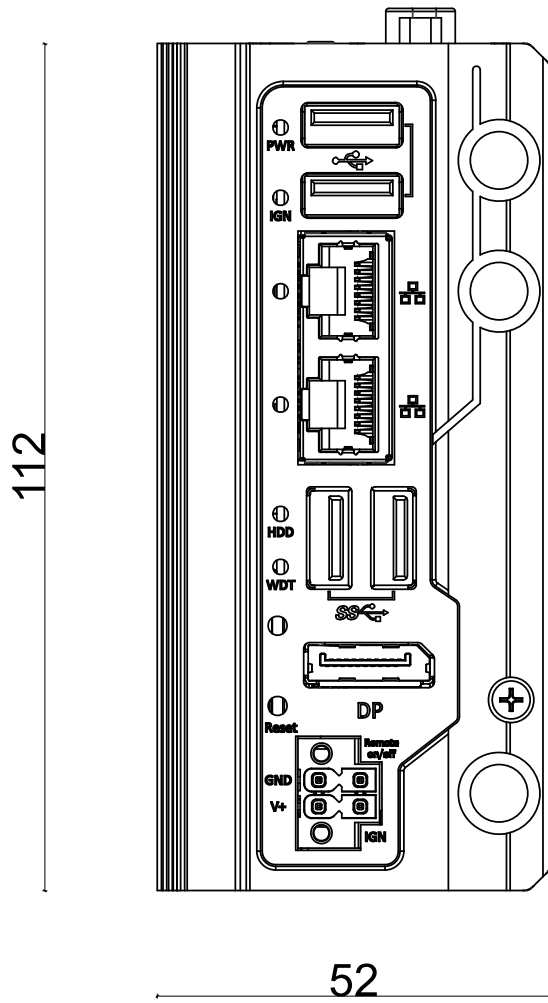



### 1.3.3 Bottom View

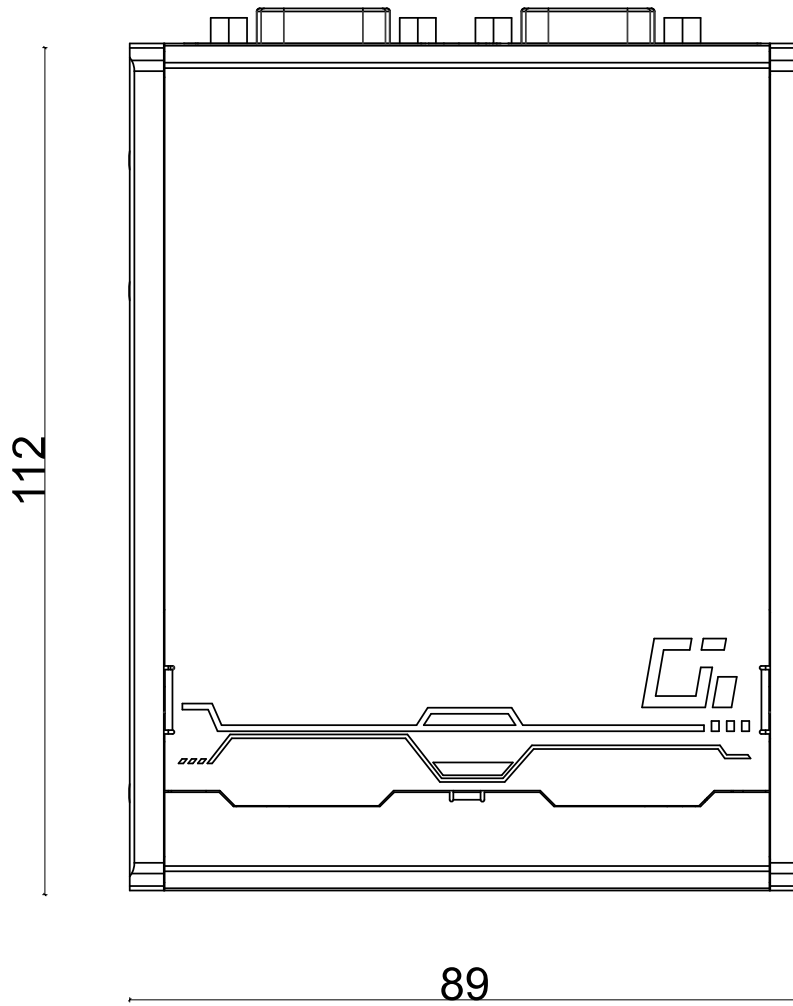

### 1.3.4 Top Panel View

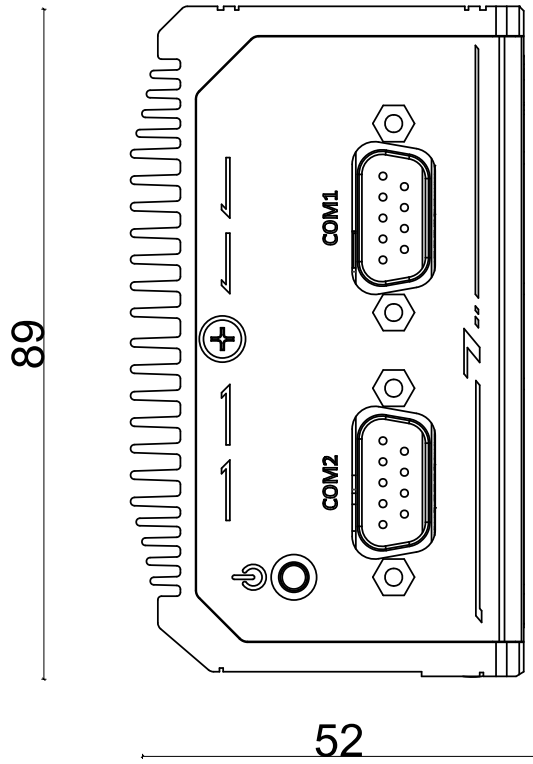

### 1.3.5 DIO Panel View

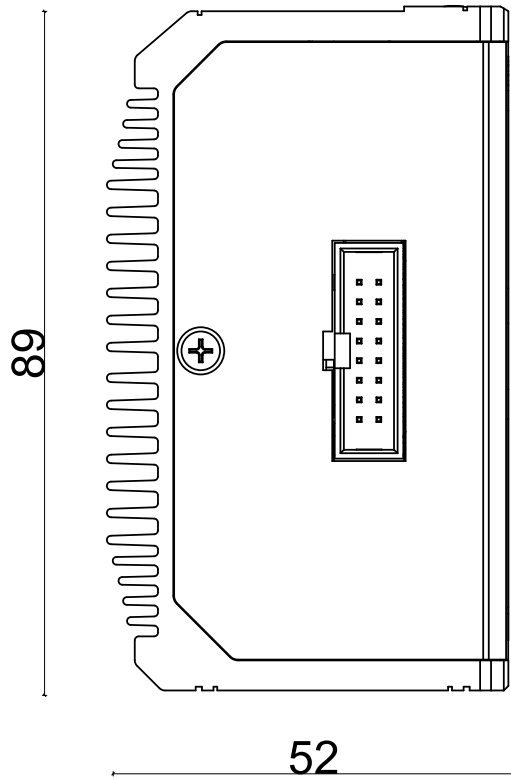

## 2 System Overview

Upon receiving and unpacking your POC-40/ POC-40+ series, please check immediately if the package contains all the items listed in the following table. If any item(s) are missing or damaged, please contact your local dealer or Neosys Technology.

### 2.1 Unpacking the System

Item	Description	Qty
1	POC-40/ POC-40+ ultra-compact fanless controller (Please verify additionally purchased accessories such as memory module, SSD, etc.)	1
2	3-pin pluggable terminal block	1
3	Neosys drivers & utilities DVD	1
4	DIN-rail mount clip	1
5	Screw package	1
6	DIO 16-pin to DB15 cable (standard on POC-40+ system)	1
7	Thermal pad 20x20mm for mini-PCIe/ M.2 module	2

## 2.2 POC-40 Series Front Panel

The front panel of POC-40/ POC-40+ systems feature rich I/O ports, it has two USB2.0, two GbE, two USB3.0 ports, a DisplayPort for video output and 4-pin terminal block for DC input.

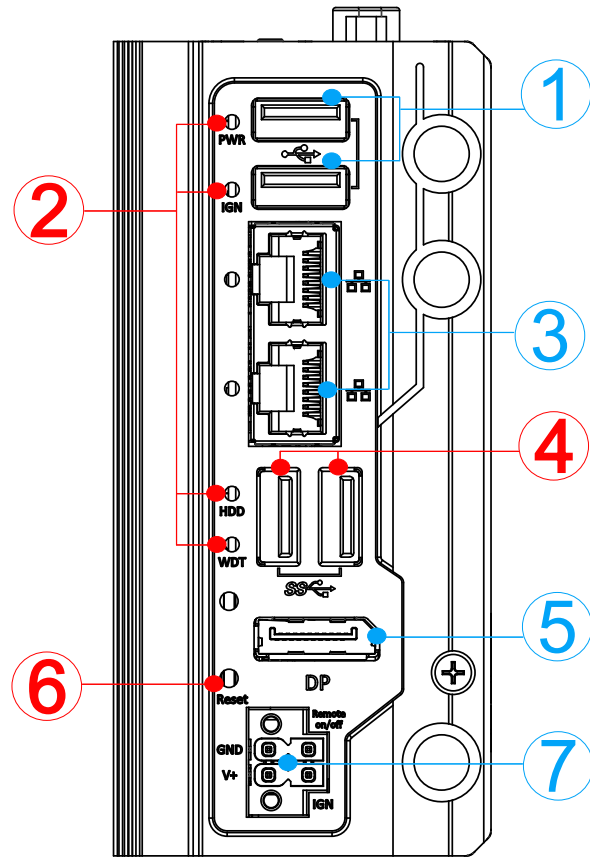

No.	Item	Description
1	<a href="#">USB 2.0 port</a>	The USB 2.0 ports offer up to 480Mbit/s bandwidth and are backward compatible with USB 1.1/ 1.0.
2	<a href="#">System status LED</a>	Four system LEDs, Power (PWR), Ignition control (IGN), Hard Disk Drive (HDD) and Watchdog Timer (WDT).
3	<a href="#">GbE port</a>	The Ethernet port offers up to 1Gb/s transfer bandwidth
4	<a href="#">USB 3.1 Gen1 port</a>	The USB 3.1 Gen1 ports support up to 5Gbit/s data transfer bandwidth and are backward compatible with USB 2.0/ 1.1/ 1.0.
5	<a href="#">DisplayPort</a>	The dual DisplayPort ports can support up to 4096 x 2160 @ 60Hz resolution each.
6	<a href="#">Reset button</a>	Use this button to manually reset the system.
7	<a href="#">4-pin terminal block (DC/ ignition input)</a>	Compatible with DC power input from 12 to 20V, the terminal block can also be used for ignition signal input.

### 2.2.1 USB 2.0 Port

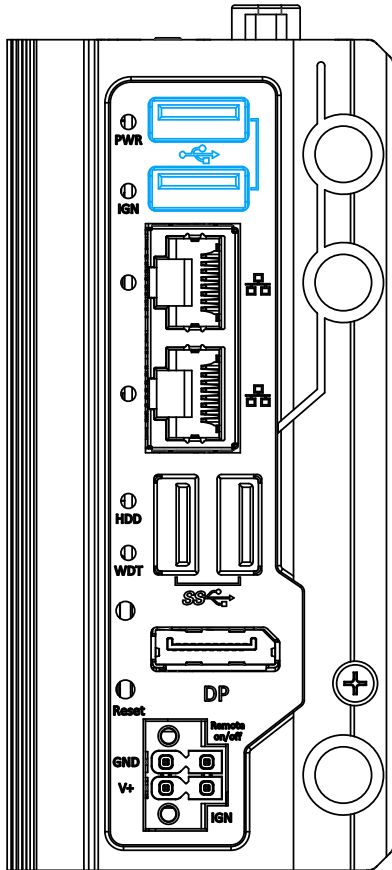

The USB2.0 ports are implemented via native xHCI (eXtensible Host Controller Interface) and are backward compatible with USB 1.1 and USB 1.0 devices. Legacy USB support is also provided so you can use USB keyboard/ mouse in DOS environment.

xHCI driver is supported natively in Windows 10, therefore you do not need to install xHCI driver to utilize USB functions.

### 2.2.2 System Status LED

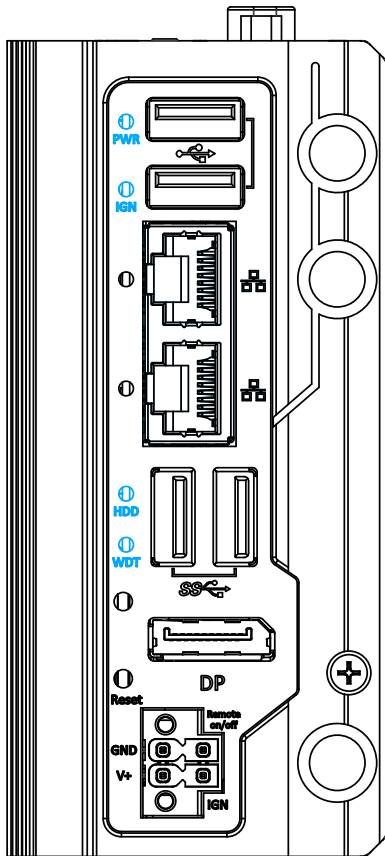

There are four LED indicators on the front panel: PWR, HDD, WDT and IGN. The descriptions of these four LEDs are listed in the following table.

Indicator	Color	Description
PWR	Green	Power indicator, lid when system is on
IGN	Green	This LED is used to indicate ignition signal status (lid when IGN signal is applied).
HDD	Red	Hard drive indicator, flashing when SATA HDD is active
WDT	Yellow	Watchdog timer indicator, flashing when watchdog timer has started

### 2.2.3 GbE Port

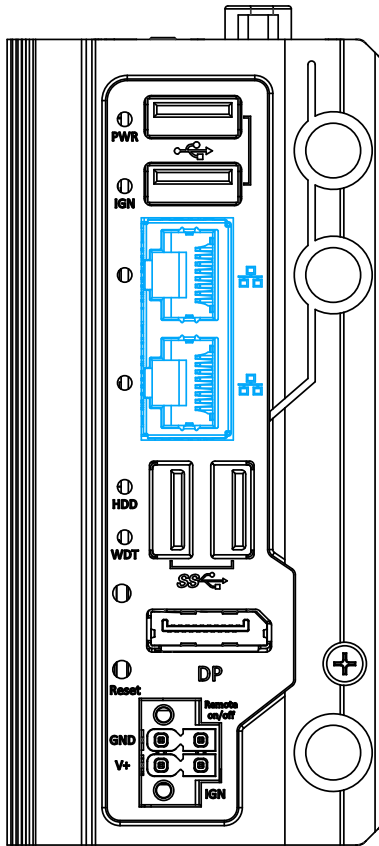

The system offers two Gigabit Ethernet ports using Intel® I210 GbE controller. When plugged in and connected via the Ethernet cable, the LEDs on the RJ45 connector indicate connection status and speed.

#### Active/Link LED (Right)

LED Color	Status	Description
Yellow	Off	Ethernet port is disconnected
	On	Ethernet port is connected and no data transmission
	Flashing	Ethernet port is connected and data is transmitting/receiving

#### Speed LED (Left)

LED Color	Status	Description
Green or Orange	Off	100 Mbps
	Green	100 Mbps
	Orange	1000 Mbps

## 2.2.4 USB 3.1 Gen1 Port

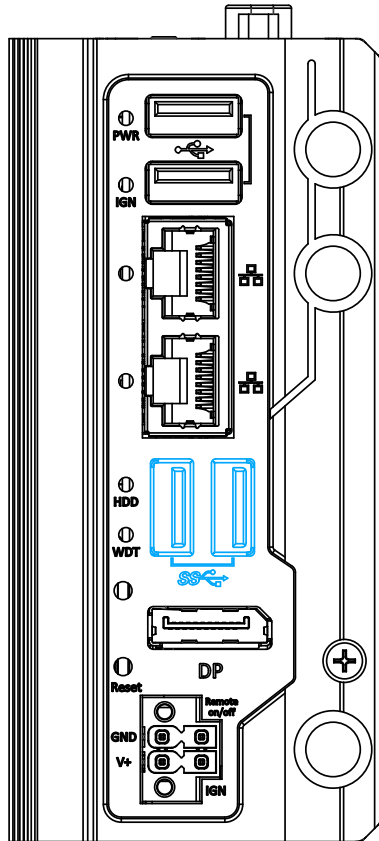

The system offers two USB 3.0 (SuperSpeed USB) ports on its front panel. They are implemented by native xHCI (eXtensible Host Controller Interface) controller and are backward compatible with USB 2.0, USB 1.1 and USB 1.0 devices. Legacy USB support is also provided so you can use USB keyboard/mouse in DOS environment. xHCI driver is supported natively in Windows 10, therefore you do not need to install xHCI driver in prior to utilize USB function.



## 2.2.5 DisplayPort

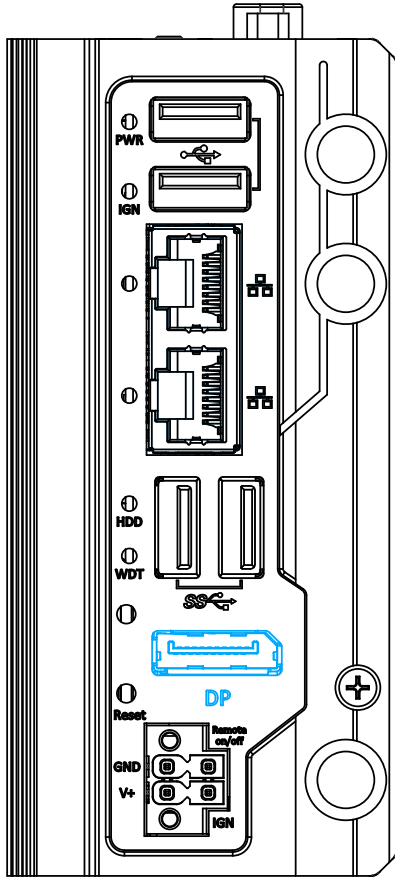

The system has a DisplayPort (DP) output which is a digital display interface that mainly connect video source and carry audio to a display device. When connecting a DP, it can deliver up to 4K UHD (4096 x 2160 @ 60Hz) in resolution. The system is designed to support passive DP adapter/ cable. You can connect to other display devices using DP-to-HDMI cable or DP-to-DVI cable.



**DP-to-HDMI**



**DP-to-DVI**

To achieve best DisplayPort output resolution in Windows, you need to install corresponding graphics drivers. Please refer to section [OS Support and Driver Installation](#) for details.

## 2.2.6 Reset Button

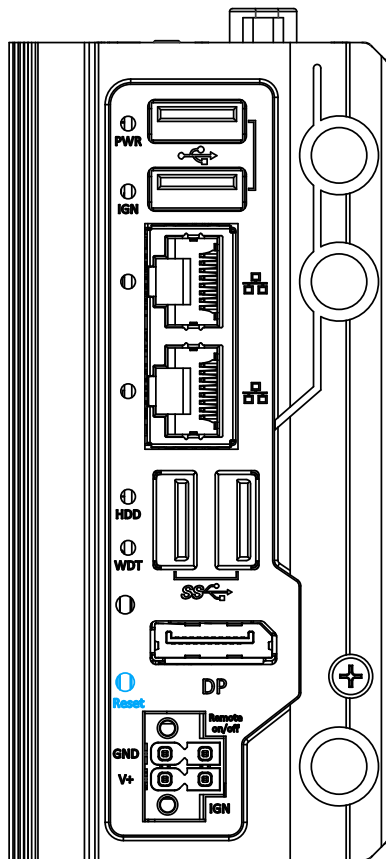

The reset button is used to manually reset the system in case of system halt or malfunction. To avoid unexpected reset, the button is purposely placed behind the panel. To reset, please use a pin-like object (eg. tip of a pen) to access the reset button.

## 2.2.7 4-Pin Terminal Block

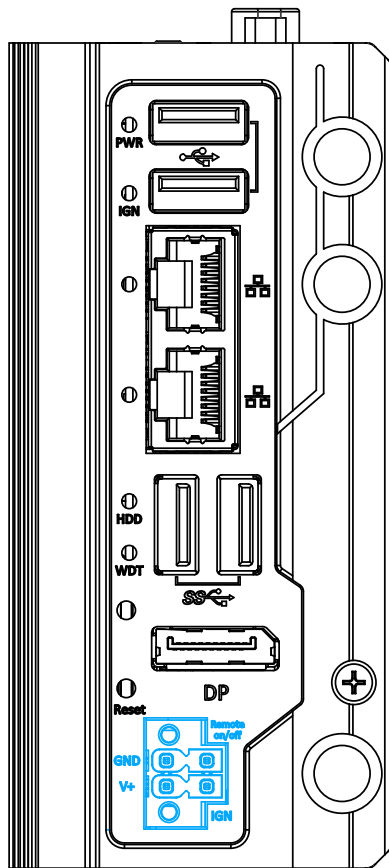

The system accepts a wide range of DC power input from 12 to 20V via a 4-pin pluggable terminal block, which is fit for field usage where DC power is usually provided.

In addition to DC power input, this terminal block can also accept ignition signal input (IGN).

The Remote On/ Off connection allows for the connection of an external non-latched switch to turn on/ off the system. It is useful when the system is placed in a cabinet or at a location not easily accessed.

The screw clamping mechanism on the terminal block offers connection reliability when wiring DC power.



### WARNING

*Please make sure the voltage of DC power is correct before you connect it to the system. Supplying a voltage over 20V will damage the system.*

## 2.3 POC-40 Series Top Panel

The top panel of POC-40 series features additional I/O functions, such as a 3.5mm speaker-out/ microphone-in jack, COM ports and antenna holes for antenna installation.

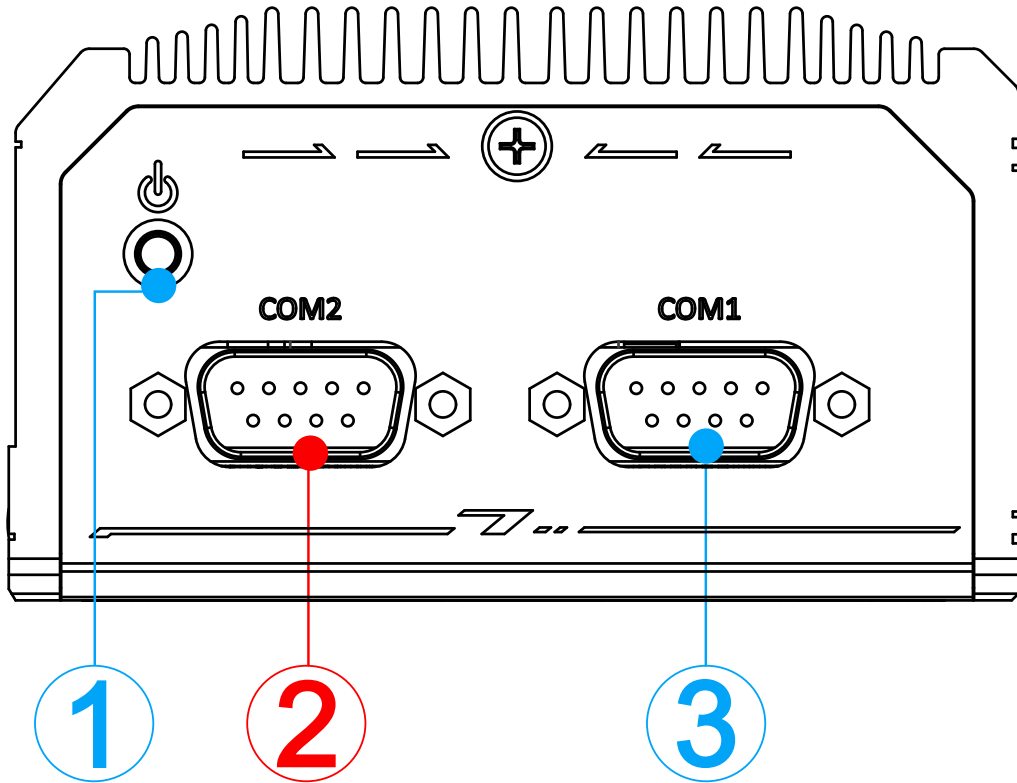

No.	Item	Description
1	<a href="#">Power button</a>	Use this button to turn on or shutdown the system.
2	<a href="#">COM port 2</a>	<b>POC-40:</b> Three 3-wire RS-232 port <b>POC-40+:</b> One isolated RS-422/ 485 port with 15 kv ESD protection
3	<a href="#">COM port 1</a>	Software programmable RS-232/ 422/ 485 port

### 2.3.1 Power Button

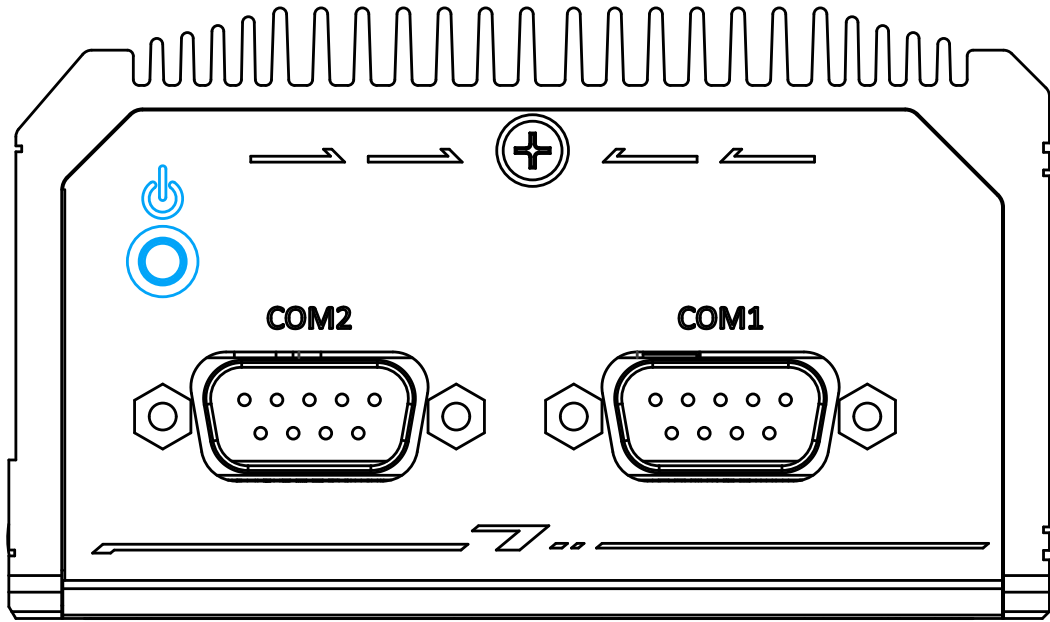

The power button is a non-latched switch for ATX mode on/off operation. Press to turn on the system, PWR LED should light up and to turn off, you can either issue a shutdown command in the OS, or just press the power button. In case of system halts, you can press and hold the power button for 5 seconds to force-shutdown the system. Please note that there is a 5 seconds interval between two on/off operations (i.e. once turning off the system, you will need to wait for 5 seconds to initiate another power-on operation).

### 2.3.2 COM2 Port (POC-40)

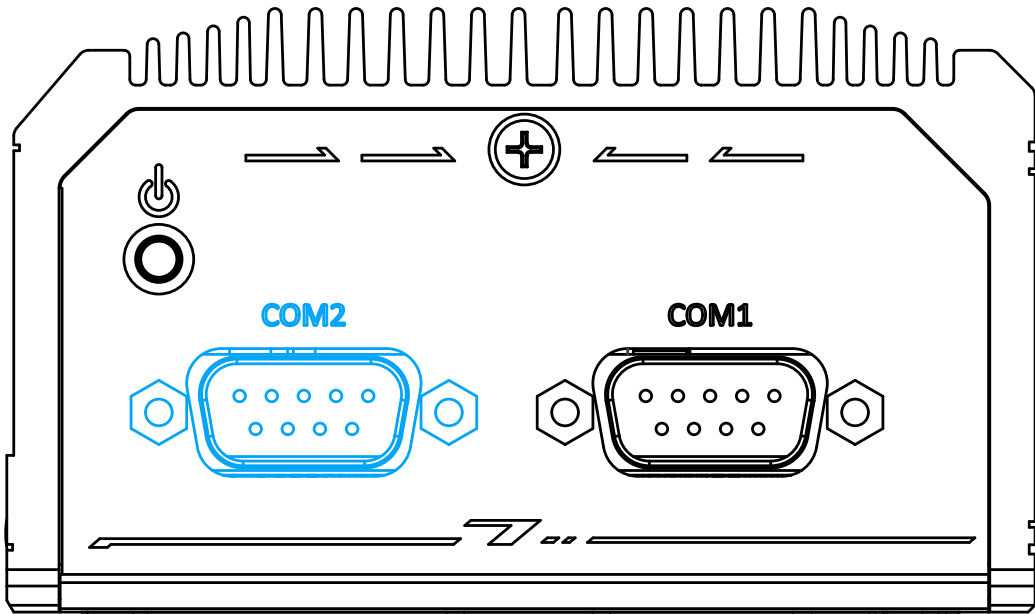

COM2 / 3/ 4 is a standard 9-wire RS-232 port. The following table describes the pin definition of COM port.

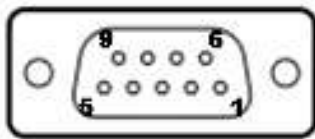

COM2/ 3/ 4 Pin



1-to-3 Y-cable

	3-port RS-232 COM2/ 3/ 4		
Pin#	COM2	COM3	COM4
1			
2	RX		
3	TX		
4		TX	
5	GND	GND	GND
6		RX	
7			TX
8			RX
9			

### 2.3.3 COM2 Port (POC-40+)

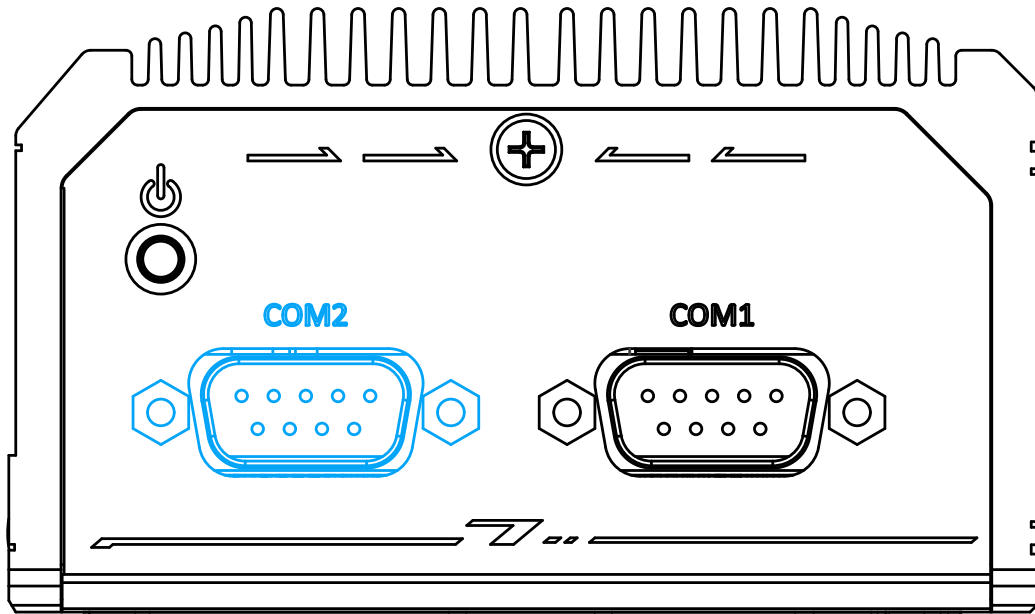

On POC-40+ system, COM2 is a One isolated RS422/485 port with 15 kV ESD protection. The following table describes the pin definition of COM port.

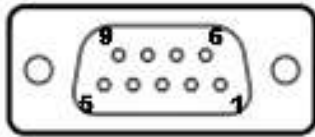

Pin	RS-422	RS-485
1		
2	TXD+	TXD+/ RXD+
3	RXD+	
4	RXD-	
5	GND	GND
6		
7		
8	TXD-	TXD-/ RXD-
9		

### 2.3.4 COM1 Port

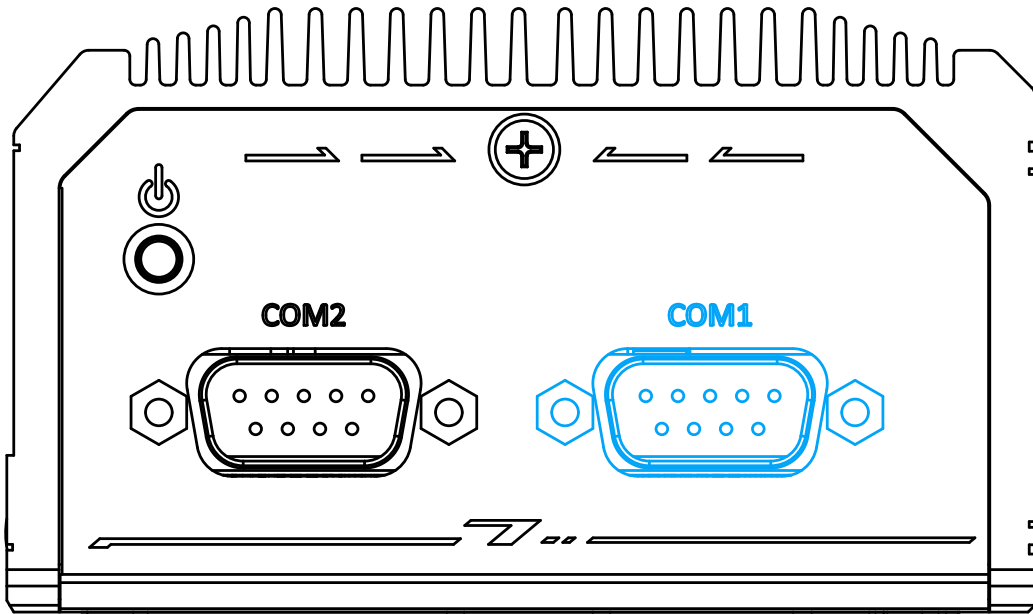

COM1 is a software-configurable RS-232/422/485 port via 9-pin D-Sub male connector. The operation mode, slew rate and termination of COM1 can be set in BIOS setup utility. The following table describes the pin definition of COM ports.

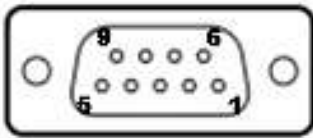

Pin#	COM1		
	RS-232 Mode	RS-422 Mode	RS-485 Mode (Two-wire 485)
1	DCD		
2	RX	422 TXD+	485 TXD+/RXD+
3	TX	422 RXD+	
4	DTR	422 RXD-	
5	GND	GND	GND
6	DSR		
7	RTS		
8	CTS	422 TXD-	485 TXD-/RXD-
9	RI		



### 2.3.5 Isolated Digital Input/ Output (POC-40+/ POC-40-DIO Only)

The system provides 4x isolated digital input channels and 4x isolated digital output channels. The DIO functions support polling mode I/O access and DI change-of-state interrupt. Please refer to [Watchdog Timer & Isolated DIO](#) for information on wiring and programming the isolated DIO channels.

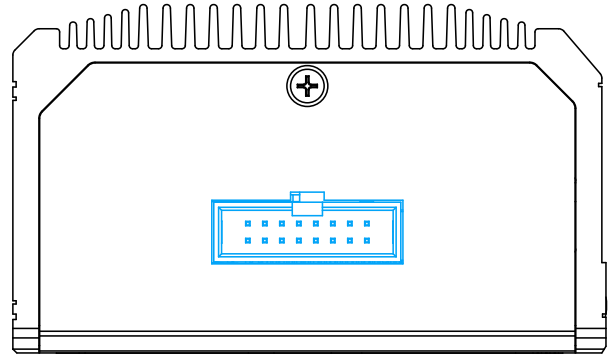

#### Isolated Digital Input

No. of Channel	4-CH Isolated Digital Input Channels
Logic Level	Logic High: 5 to 24V Logic Low: 0 to 1.5V
Isolated Voltage	2500 Vrms
Input Resistance	1kΩ
Operation Mode	Polling

#### Isolated Digital Output

No. of Channel	4-CH Isolated Digital Output Channels
Sink Current (per channel)	500 mA
Isolated Voltage	1500 Vrms
Operation Mode	Polling

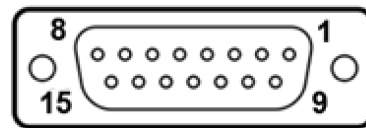
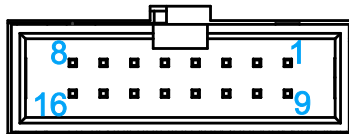

System DIO port

DB15 connector end

Pin#	Pin Definition	Pin#	Pin Definition
1	DI_0	9	DI_GND
2	DI_1	10	DI_2
3	DI_GND	11	DI_3
4	DO_GND	12	DO_GND
5	DO_0	13	DO_2
6	DO_1	14	DO_3
7	DO_GND	15	-
8	VDD		

When using DO0 – DO3, DO\_GND should be connected also.

### Wiring for DIO

The digital input function is implemented using a photo-coupler with an internally series-connected 1kΩ resistor. You need to provide a voltage to specify the logic high/low state. The input voltage for logic high is 5~24V, and the input voltage for logic low is 0~1.5V.

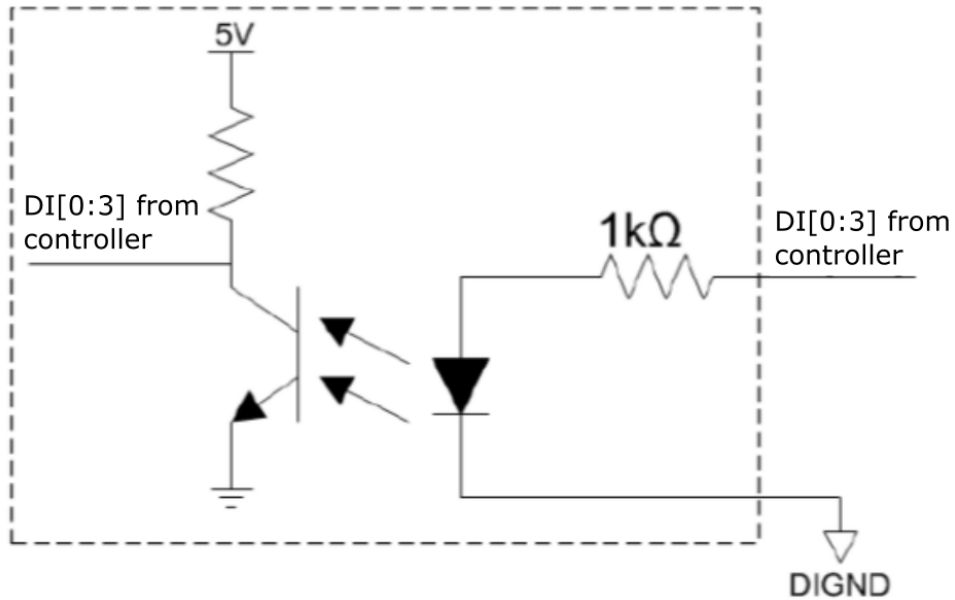

The digital output function is implemented using Power MOSFET + Analog Device iCoupler® component. The DO channels are configured as NO (normally-open) configuration. When you turn on the system, all DO channels have a deterministic state of logic 0 (circuit disconnected from GND return). When logic 1 is specified, MOSFET is activated and GND return path is established. The digital output function on the system supports sinking current connection. The following diagrams are the suggested wiring for DO:

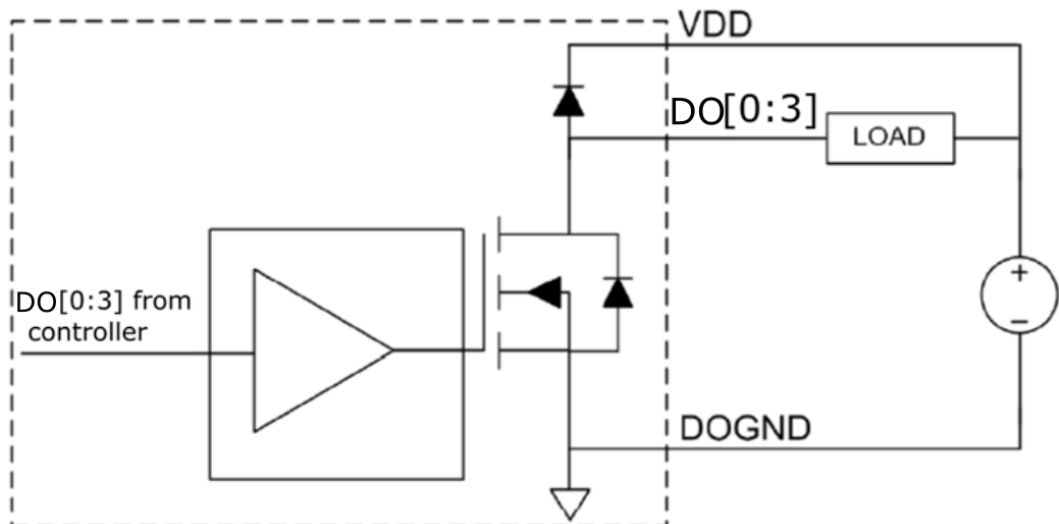

## 2.4 POC-40 Series Internal I/O

The system's internal I/O connectors consist of a SO-DIMM socket, M.2 M key, M.2 B key, and M.2 E key. There is also an MezIO™ port for application-oriented expansion purposes.

### 2.4.1 SO-DIMM Memory Socket

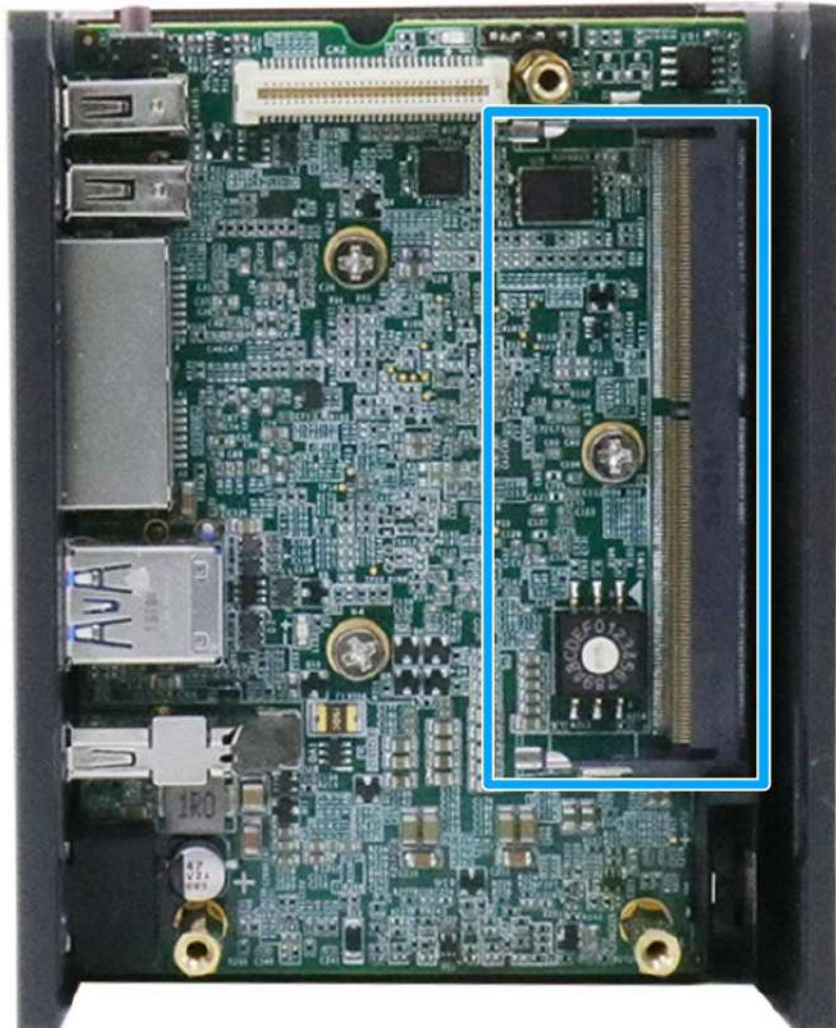

The system has an internal SO-DIMM slot supporting DDR4-3200 memory module up to 32GB in capacity.

## 2.4.2 M.2 M Key Slot for SSD (SATA Signal Only)

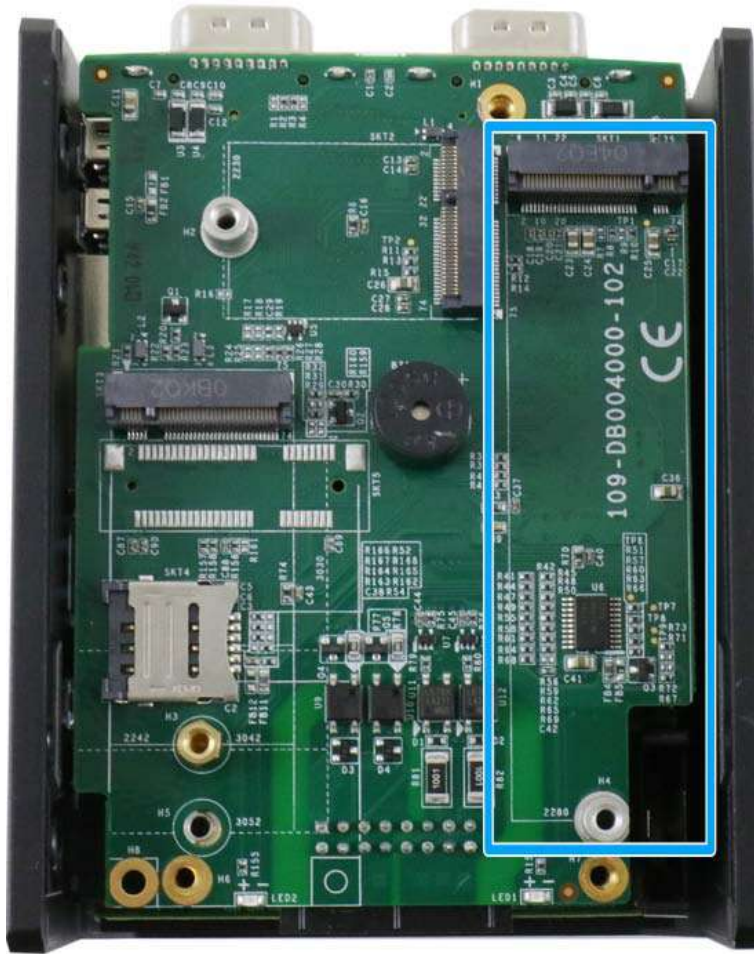

The system has an M.2 2280 slot (SATA signal only) for you to install an M.2 SATA SSD for faster access over traditional hard disk drives.



### NOTE

*The M.2 slot is only compatible with SATA signal M.2 SSD only.*

**M.2 2280 M Key Pin Definition**

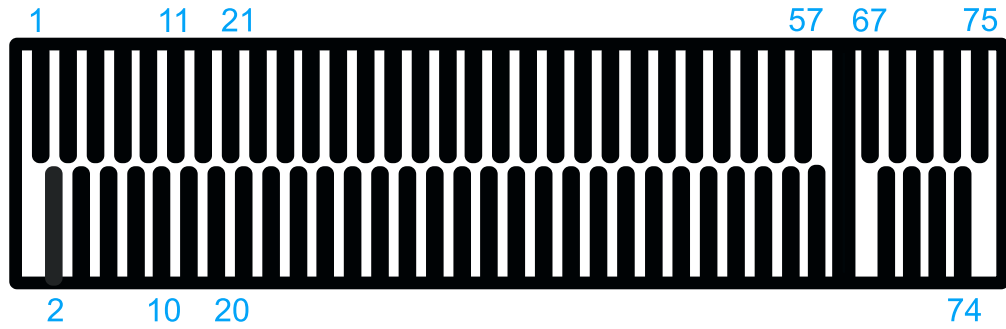

Pin #	Signal	Pin #	Signal
1	GND	2	+3V3
3	GND	4	+3V3
5		6	-
7		8	-
9	GND	10	DAS/DSS N
11		12	+3V3
13		14	+3V3
15	GND	16	+3V3
17		18	+3V3
19		20	-
21	GND	22	-
23		24	-
25		26	-
27	GND	28	-
29		30	-
31		32	-
33	GND	34	-
35		36	DEVSLP
37		38	-
39	GND	40	-
41	SATA-B+	42	-
43	SATA-B-	44	-
45	GND	46	-
47	SATA-A-	48	-
49	SATA-A+	50	PERST N
51	GND	52	-
53		54	-
55		56	-
57	GND	58	-
<b>Mechanical Key</b>			
67	-	68	SUSCLK
69	PEDET	70	+3V3
71	GND	72	+3V3
73	GND	74	+3V3
75	GND		

### 2.4.3 M.2 3042/ 3052 B Key Socket (POC-40 Only)

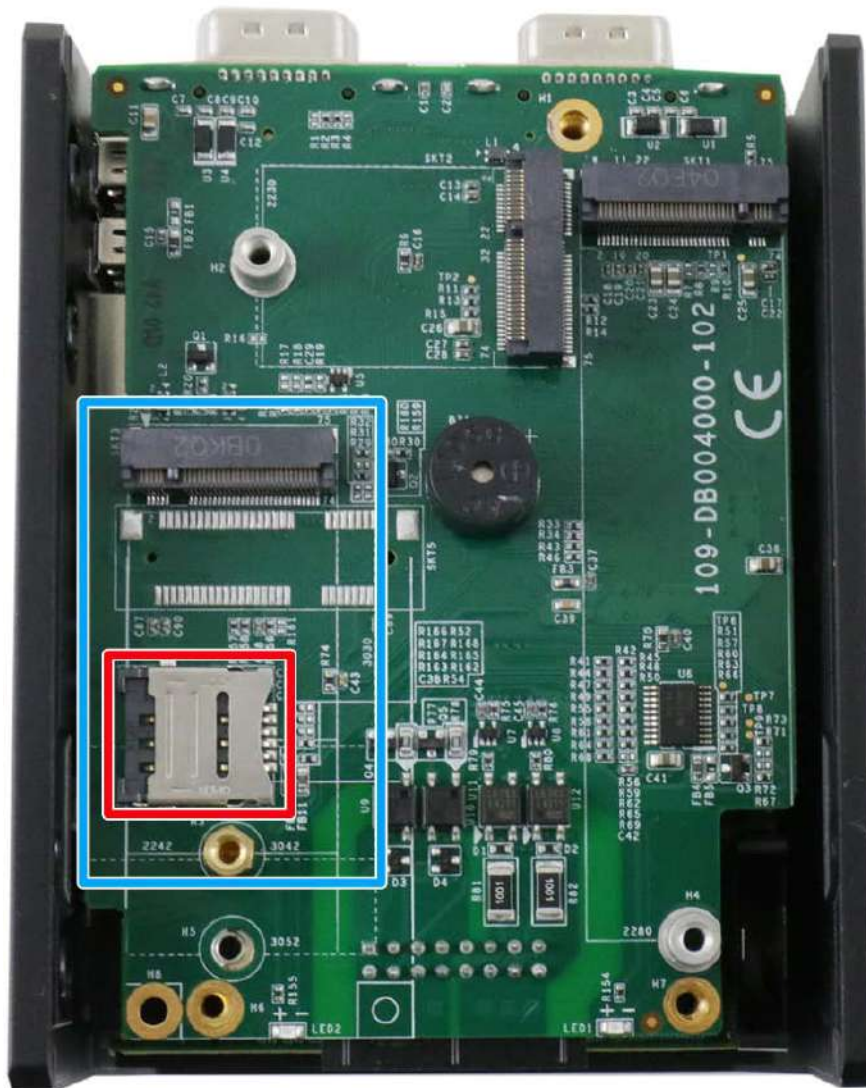

The system has one M.2 3042/ 3052 B key socket (in blue) with USB3.1 Gen 1 and USB 2.0 signal for 4G/ 5G module installation. There is also a corresponding micro-SIM SIM card slot (in red).

For SMA antenna installation, there are three dedicated openings located on the front of the chassis.



M.2 3042/ 3052 B Key Pin Definition

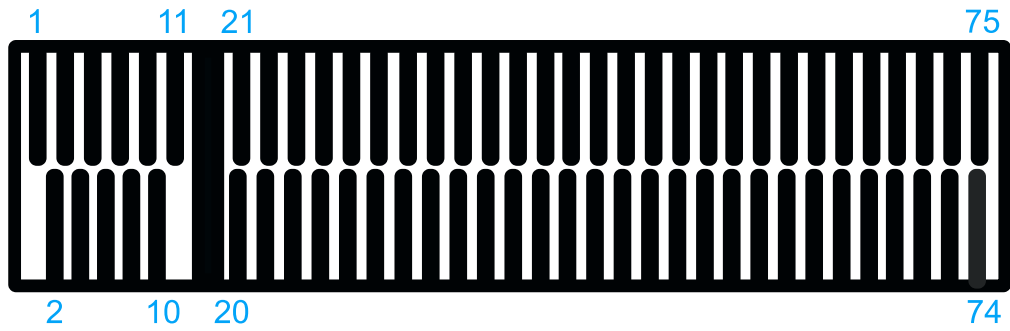

Pin #	Signal	Pin #	Signal
1	-	2	+3V3
3	GND	4	+3V3
5	GND	6	FULL_CARD_POWER_OFF_N
7	USB_D+	8	W_DISABLE_N
9	USB_D-	10	-
11	GND		
<b>Mechanical Key</b>			
21	-	20	-
23	-	22	-
25	-	24	-
27	GND	26	-
29	USB3.0-RX-	28	-
31	USB3.0-RX+	30	UIM1-RESET
33	GND	32	UIM1-CLK
35	USB3.0-TX-	34	UIM1-DATA
37	USB3.0-TX+	36	UIM1-PWR
39	GND	38	-
41		40	
43		42	
45	GND	44	
47		46	
49		48	
51	GND	50	PERST_N
53		52	-
55		54	-
57	GND	56	-
59	-	58	-
61	-	60	-
63	-	62	-
65	-	64	-
67	RESET_N	66	
69	CONFIG_1	68	-
71	GND	70	+3V3
73	GND	72	+3V3
75	-	74	+3V3

### 2.4.4 Mini-PCIe Socket (POC-40+ Only)

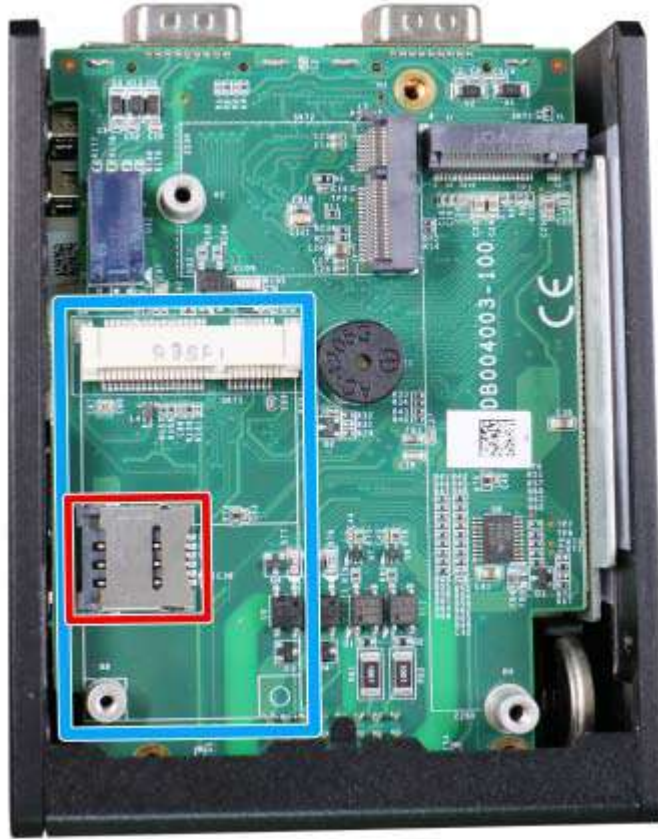

The system provides a mini-PCIe socket (indicated in **blue**) that is in compliance with mini-PCIe specification rev. 1.2. This mini-PCIe socket is designed with SIM card (slot indicated in **red**) support. With a SIM card installed, your system can access the internet via your network provider’s 4G/ 3G network.

For wireless (WiFi/ 4G/ 3G) communication, multiple SMA antenna apertures can be located on the front and rear panel.

For SMA antenna installation, there are three dedicated openings located on the front of the chassis.





**mini-PCle socket definition**

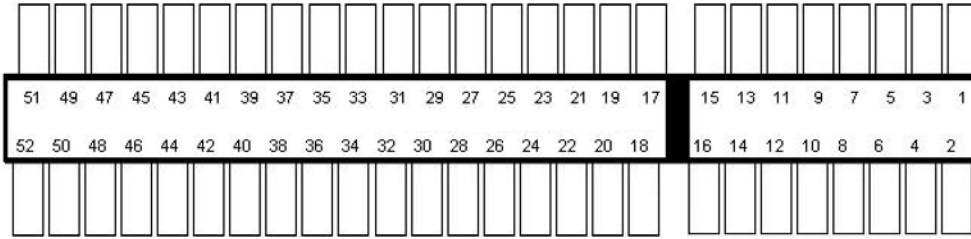

Pin	Signal (mPCle)	Pin #	Signal (mPCle)
1	WAKE#	2	+3.3Vaux
3	-	4	GND
5	-	6	+1.5V
7	CLKREQ#	8	UIM_PWR
9	GND	10	UIM_DATA
11	REFCLK-	12	UIM_CLK
13	REFCLK+	14	UIM_RESET
15	GND	16	UIM_VPP
<b>Mechanical Key</b>			
17	Reserved* (UIM_C8)	18	GND
19	Reserved* (UIM_C4)	20	W_DISABLE#
21	GND	22	PERST#
23	PERn0	24	3.3V
25	PERp0	26	GND
27	GND	28	+1.5V
29	GND	30	SMB_CLK
31	PETn0	32	SMB_DATA
33	PETp0	34	GND
35	GND	36	USB_D-
37	GND	38	USB_D+
39	3.3V	40	GND
41	3.3V	42	-
43	GND	44	-
45	Reserved	46	-
47	Reserved	48	+1.5V
49	Reserved	50	GND
51	Reserved	52	3.3V



**WARNING**

*Some off-the-shelf mini-PCle 5G/4G modules are not compliant to standard mini-PCle interface. They use 1.8V I/O signals instead of standard 3.3V I/O and may cause signal conflict. Please consult with Neousys for compatibility when in doubt! Installing an incompatible 4G module may damage the system or the module itself may be damaged.*

### 2.4.5 M.2 E Key Socket



The system has an M.2 2230 E key socket that offers PCIe Gen3 x1 and USB2.0 signal for WiFi module installation.

For SMA antenna installation, there are three dedicated openings located on the front of the chassis.



**M.2 2230 E Key Pin Definition**

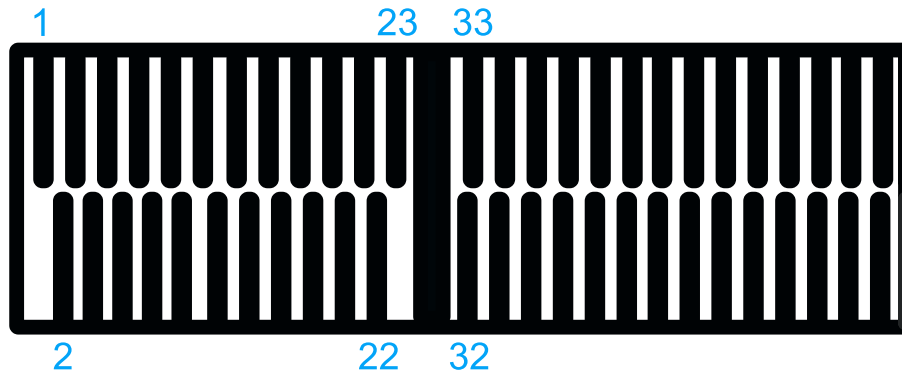

Pin #	Signal	Pin #	Signal
1	GND	2	+3V3
3	USB_D+	4	+3V3
5	USB_D-	6	
7	GND	8	
9		10	-
11		12	
13		14	
15		16	
17		18	GND
19		20	
21	-	22	-
23	-		
Mechanical Key			
33	GND	32	
35	PETP0	34	
37	PETN0	36	
39	GND	38	
41	PER P0	40	
43	PER N0	42	
45	GND	44	
47	REFCLK_P0	46	
49	REFCLK_N0	48	
51	GND	50	
53	CLKREQ#	52	PERST#
55		54	
57	GND	56	W_DISABLE#
59		58	
61		60	
63	GND	62	
65		64	
67		66	
69	GND	68	
71		70	
73		72	+3V3
75	GND	74	+3V3

## 2.4.6 Ignition Rotary Switch (IGN Models Only)



The IGN models feature an ignition control switch that has multiple modes for pre and post ignition settings. Please refer to the section [Ignition Power Control](#) for details.

## 3 System Installation

Before disassembling the system enclosure and installing components and modules, please make sure you have done the following:

- It is recommended that only qualified service personnel should install and service this product to avoid injury or damage to the system.
- Please observe all ESD procedures at all times to avoid damaging the equipment.
- Before disassembling your system, please make sure the system has powered off, all cables and antennae (power, video, data, etc.) are disconnected.
- Place the system on a flat and sturdy surface (remove from mounts or out of server cabinets) before proceeding with the installation/ replacement procedure.

### 3.1 Disassembling the System Enclosure

To install necessary components such as memory, SIM card, WiFi, or M.2 SATA SSD, you need to disassemble the POC-40 system enclosure:

1. To disassemble POC-40, unfasten the screws shown on the COM port panel.



2. Unfasten the screw on the two panels.



COM port panel



Front panel

3. Gently slide the L-shaped enclosure open (in the directions shown) and remove the side panel to gain access to internal I/O connectors.



**Slide open the L-shape panel**

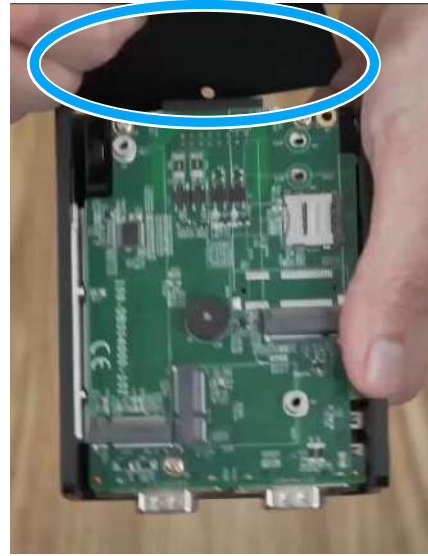

**Remove the side panel**

4. Remove the screws and gently lift the daughter board on top.



**Remove the screws**



**Top daughter board removed**

5. To gain access to the DRAM slot and ignition rotary switch, un-screw the screws on the side of the enclosure to remove the DRAM heatsink.



Remove the screws

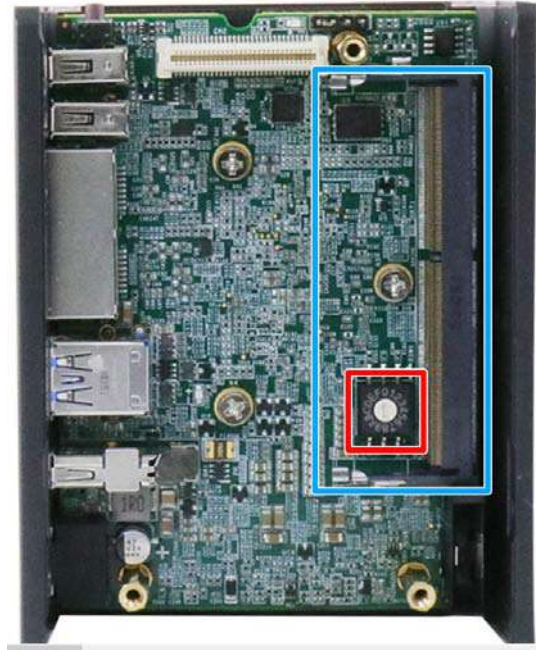

DRAM slot and ignition switch

To watch an unboxing video on how to disassemble POC-40, please refer to this [link](#).



## 3.2 Installing Internal Components

### 3.2.1 DDR4 SO-DIMM Installation

There is one SO-DIMM memory slot on POC-40 series motherboard. Please follow the procedures below to install the memory module.

1. [Disassemble the system enclosure](#)
2. The SO-DIMM slot can be located once the enclosure has been removed, and the top daughter board removed.



3. **To install**, insert the gold finger end of the SO-DIMM on a 45 degree angle into the slot and gently push the SO-DIMM down until it clips-in.



### 3.2.2 M.2 3042/ 3052 B Key Module Installation (POC-40 Only)

There is an M.2 3042/ 3052 B key module with USIM expansion slot in the POC-40 system. Please follow the procedures below to install the M.2 module and micro SIM card, as well as the antenna.

1. [Disassemble the system enclosure.](#)
2. The M.2 B key module (indicated in blue) and micro SIM slot (indicated in red) can be located once the enclosure has been removed.



3. You need to install the micro SIM card first. The micro SIM card slot utilizes a slide-and-clamp mechanism. To open the slot, slide the micro SIM cover towards the center of the system and flip open the slot. Place the micro SIM card into position, place the cover over the micro SIM card, and slide the cover towards the enclosure wall to secure it.



**Place micro SIM in slot**



**Secure micro SIM with cover**

4. Once the micro SIM has been installed. Insert M.2 B key module's gold finger on a 45 degree angle into the socket, gently press the module down and secure it with a screw (indicated in blue).



5. Clip-on the module's antenna (please refer to the module's user manual on antenna cable connection).



6. Attach two 20x20mm thermal pads by stacking one on top of another onto the location shown (indicated in **blue**) on the internal wall of the L-shaped enclosure.

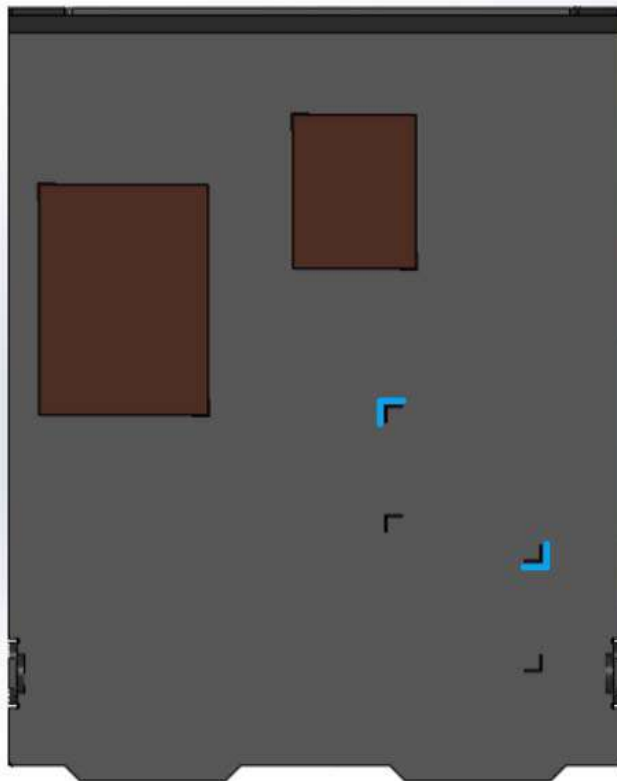

7. Remove one of the antenna cover from the enclosure.



- Please refer to the illustration below on how to secure the SMA antenna connector body. Install the antenna to complete the installation.

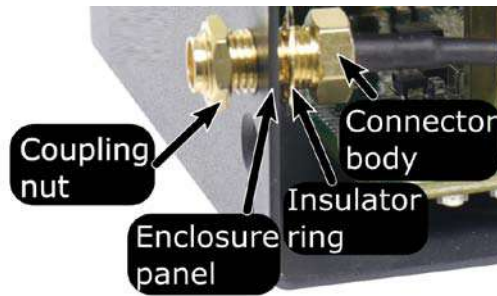

**Coupling, insulator, connector body**

**Installed on enclosure**



**Install the antenna**

- [Reinstall the system enclosure](#) and attach the external antennae to complete the installation.

### 3.2.3 mini-PCIe Module Installation (POC-40+ Only)

There is an mini-PCIe module with USIM expansion slot in the POC-40+ system. Please follow the procedures below to install the mini-PCIe module and micro SIM card, as well as the antenna.

1. [Disassemble the system enclosure.](#)
2. The mini-PCIe module (indicated in blue) and micro SIM slot (indicated in red) can be located once the enclosure has been removed.

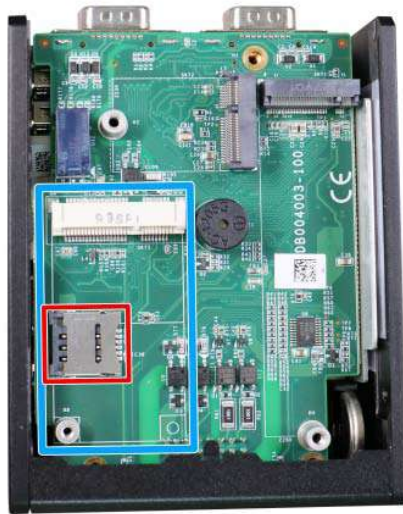

3. You need to install the micro SIM card first. The micro SIM card slot utilizes a slide-and-clamp mechanism. To open the slot, slide the micro SIM cover towards the center of the system and flip open the slot. Place the micro SIM card into position, place the cover over the micro SIM card, and slide the cover towards the enclosure wall to secure it.



**Place micro SIM in slot**



**Secure micro SIM with cover**

4. Once the micro SIM has been installed. Insert M.2 B key module's gold finger on a 45 degree angle into the socket, gently press the module down and secure it with a screw (indicated in blue).



5. Clip-on the module's antenna (please refer to the module's user manual on antenna cable connection).



- Attach two 20x20mm thermal pads by stacking one on top of another onto the location shown (indicated in **blue**) on the internal wall of the L-shaped enclosure. If you are using a mini-PCIe adaptor for an M.2 module, attach one 20x20mm thermal pad provided (can be found in the accessory box) onto the location shown (indicated in **red**) on the internal wall of the L-shaped enclosure.

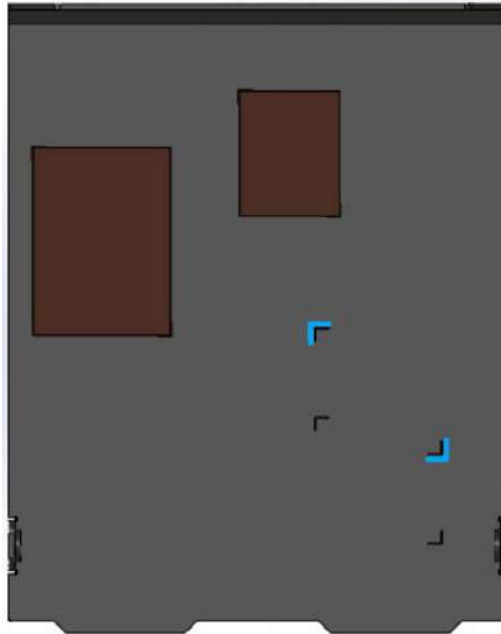

Attach 2x 20x20mm thermal pads stacked on top of one another

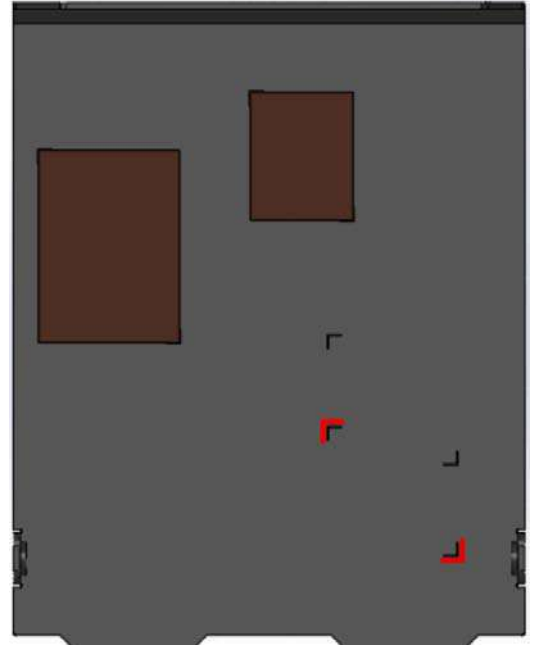

Attach 1x 20x20mm thermal pad

- Remove one of the antenna cover from the enclosure.





- Please refer to the illustration below on how to secure the SMA antenna connector body. Install the antenna to complete the installation.

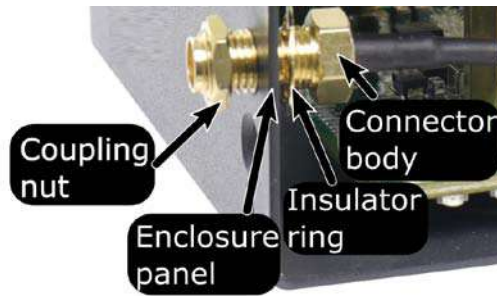

**Coupling, insulator, connector body**

**Installed on enclosure**



**Install the antenna**

- [Reinstall the system enclosure](#) and attach the external antennae to complete the installation.

### 3.2.4 M Key M.2 2280 SATA SSD Module Installation

There is a SATA signal M key M.2 2280 slot in the POC-40 system. Please follow the procedures below to install the M.2 2280 SATA SSD.

1. [Disassemble the system enclosure.](#)
2. The M.2 2280 M key slot can be located once the enclosure has been removed.

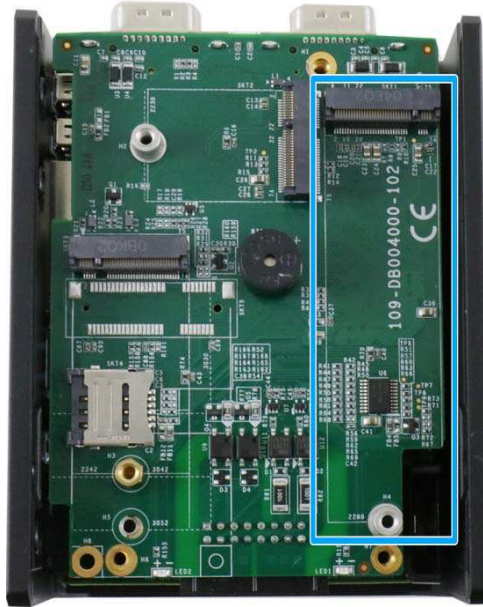

3. Insert the M.2 2280 SATA SSD module on a 45 degree angle, gently press the card down, and secure with a screw. Please remember to remove the thermal pad protection film on the L-shaped enclosure before reinstalling the enclosure.



**Secure with a screw**

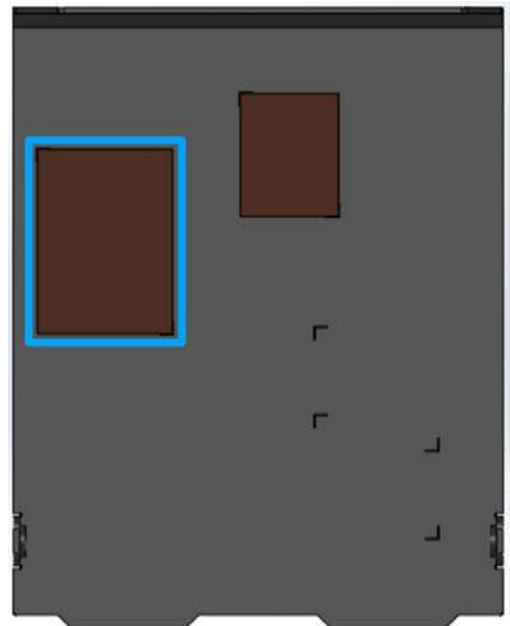

**Remove thermal pad protection film**

4. [Reinstall the system enclosure.](#)

### 3.2.5 M.2 2230 E Key Module Installation

The system has an M.2 2230 E key socket that offers PCIe Gen3 x1 and USB2.0 signal for WiFi module installation. The M.2 slot can be accessed by removing the bottom panel. Please refer to the section "[Disassembling the System](#)".

1. [Disassemble the system enclosure.](#)
2. The M.2 2230 E key slot can be located once the enclosure has been removed.



3. Insert the gold finger end of the module on a 45 degree angle into the E key slot, gently press down and secure it with a screw. Please remember to remove the thermal pad protection film on the L-shaped enclosure before reinstalling the enclosure.

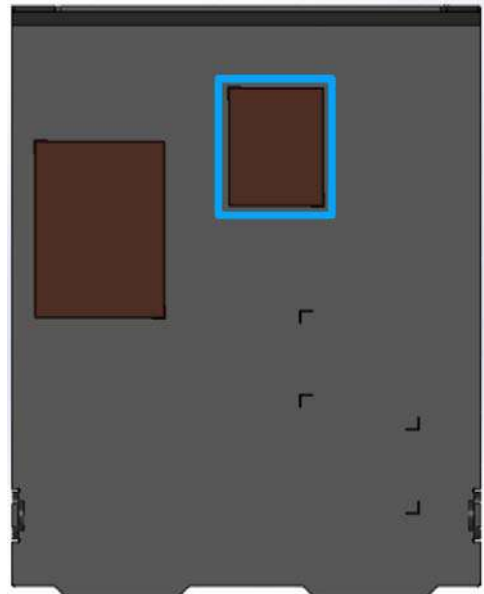

**Secure with a screw**

4. [Reinstall the system enclosure.](#)

### 3.3 Installing the System Enclosure

1. To reinstall the system enclosure, install and secure the side panel.



Install the side panel



Secure the side panel

2. gently slide the L-shaped enclosure back in place making sure the screw hole on the hinge sits on the inside.



- Secure the screw on the front panel.



- Complete installing the system enclosure by fastening the screws indicated.



### 3.4 DIN Rail Installation

The DIN rail is easy to install and it is a convenient way to position the system. The Din rail has been proven to be most beneficial in the industrial environment where space is limited. The mount plate comes with two M4 screws. Please refer to the illustrations below to install the DIN clip/ rail.

1. To install, secure the DIN rail clip onto the rear of the system enclosure using the M4 screws provided (indicated in blue).



2. To install the mount plate onto the DIN rail, you must come over the top of the DIN rail, tilting downwards, overlap the top clip edge of the mount plate onto the DIN rail first, then firmly press the bottom-front of the enclosure to clip the bottom edge of the mount plate.

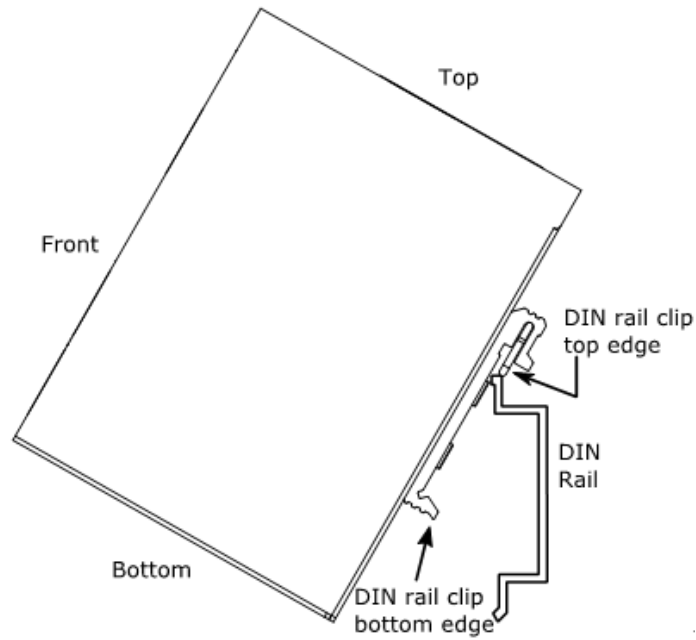

## 3.5 Powering On the System

There are five methods to power on the system

- Pressing the power button
- Via an external non-latched switch
- Using the ignition signal input

We will describe the processes and actions involved for the first two methods in this section and the ignition signal input method will be described in section 3.6.

### 3.5.1 Powering On Using the Power Button

This is the simplest way to turn on your system. The power button on the front panel is a non-latched switch and behaves as the ATX-mode on/off control. With DC power connected, pushing the power button will turn on the system and the PWR LED indicator will light up. Pushing the button when system is on will turn off the system. If your operating system supports ATX power mode (i.e. Microsoft Windows or Linux), pushing the power button while the system is in operation will result in a pre-defined system behavior, such as shutdown or hibernation.

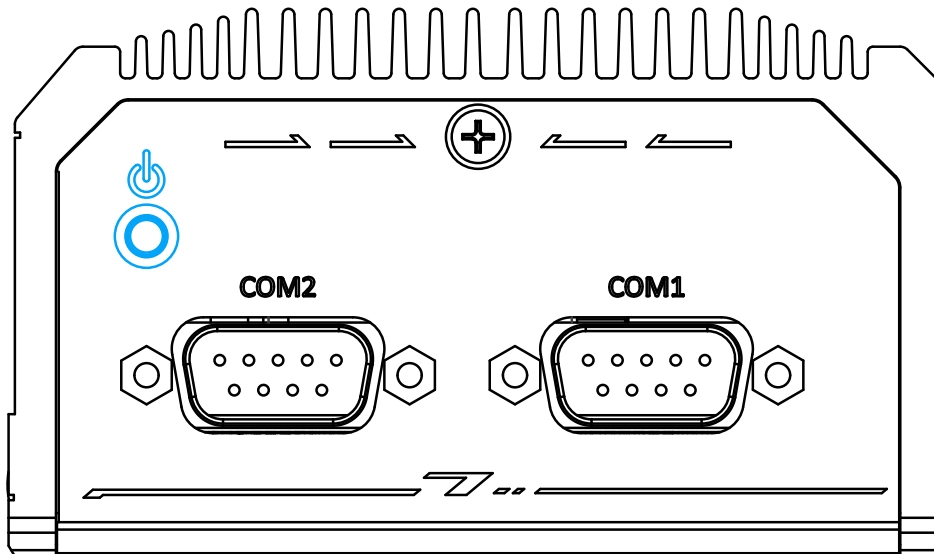



### 3.5.2 Powering On Using An External Non-Latched Switch

For an application which places the system inside a cabinet, it's useful to control powering on/off the system using an external switch. The system provides an on-board connector for connecting a latched/ non-latched switch and behaving either AT-mode or ATX-mode power on/off control.

When using the ATX-mode on/ off control, you need a non-latch switch. The external non-latched switch acts exactly the same as the power button on the front panel. Please follow the steps below to install an external non-latch switch.

1. Prepare a non-latched switch with a 2-pin plug.
2. Connect the 2-pin non-latched switch to the remote on/ off and GND pin.

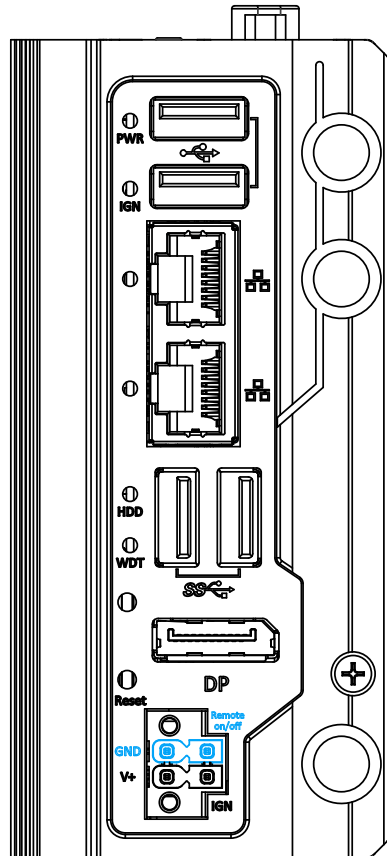

3. With DC power connected, pushing the power button will turn on the system and the PWR LED indicator will light up. Pushing the button when system is on will turn off the system. If your operating system supports ATX power mode (i.e. Microsoft Windows or Linux), pushing the power button while the system is in operation will result in a pre-defined system behavior, such as shutdown or hibernation.

### 3.5.3 Powering On Using Wake-on-LAN

Wake-on-LAN (WOL) is a mechanism to wake up a computer system from a S3 (standby), S4 (Hibernate) or S5 (system off with standby power) state via issuing Subnet Directed Broadcasts (SDB) or a magic packet. The system implements the Wake-on-LAN function for the Ethernet port shown below.

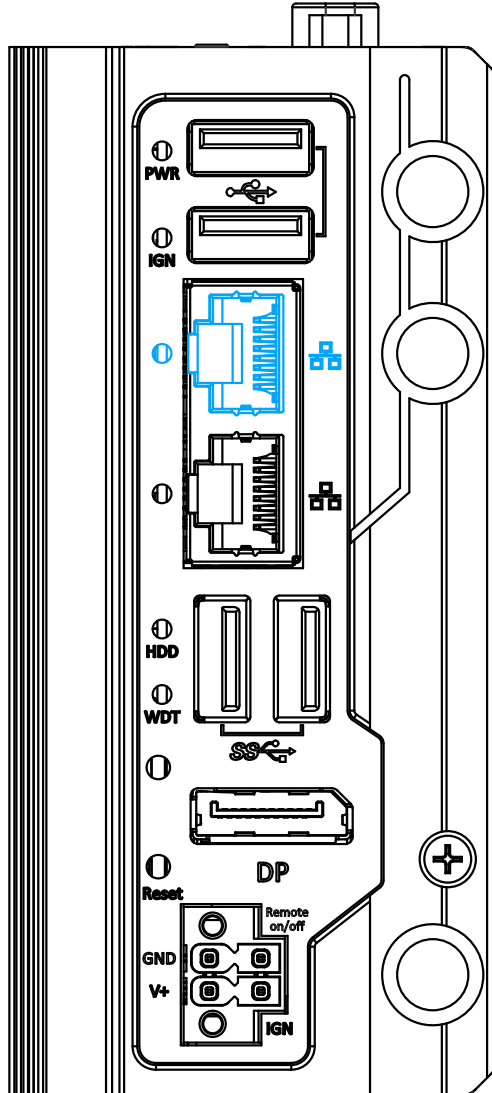

To enable WOL function and power on your system, please follow the steps below.

1. Press F2 when the system boots up to enter BIOS.
2. Enter the **[Power]** menu. And configure the **[Wake On LAN]** option as **[Enabled]**. Please refer to the [Wake-on-LAN](#) section.

- In Windows systems, identify the Local Area Connection of the corresponding Gigabit Controller and click the **Configure** button.

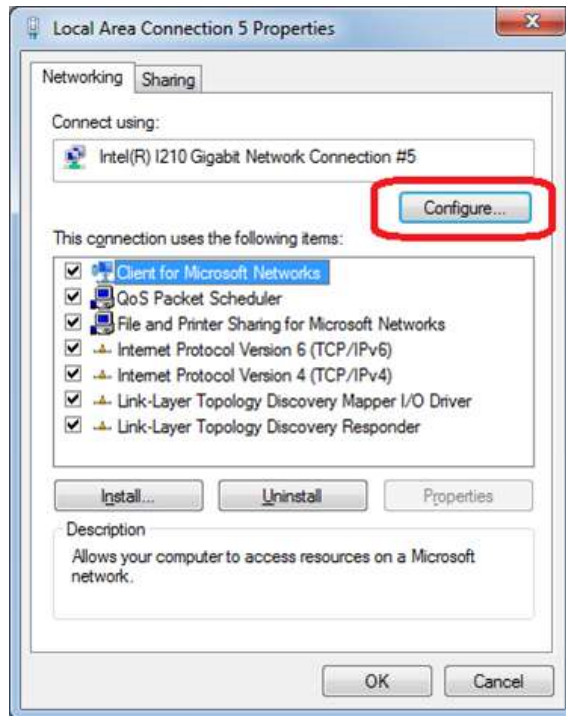

- Click the **Power Management** tag, and check the following two options accordingly

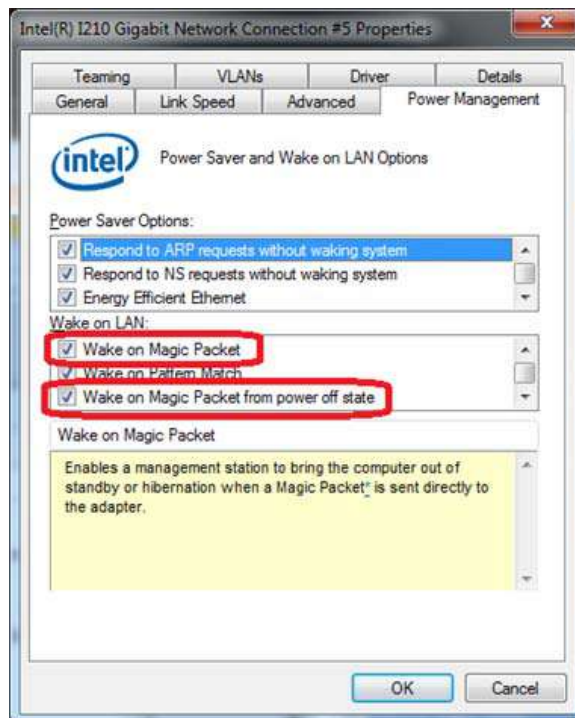

- **Wake on Magic Packet**

The system can wake from S3 or S4 state when receiving a magic packet. The magic packet is a broadcast frame containing anywhere within its payload 6 bytes of all 255 (FF FF FF FF FF FF in hexadecimal), followed by sixteen repetitions of the target computer's 48-bit MAC address.

For example, NIC's 48-bit MAC Address is 78h D0h 04h 0Ah 0Bh 0Ch

DESTINATION SOURCE MISC

FF FF FF FF FF FF

78 D0 04 0A 0B 0C 78 D0 04 0A 0B 0C

78 D0 04 0A 0B 0C 78 D0 04 0A 0B 0C

78 D0 04 0A 0B 0C 78 D0 04 0A 0B 0C

78 D0 04 0A 0B 0C 78 D0 04 0A 0B 0C

78 D0 04 0A 0B 0C 78 D0 04 0A 0B 0C

78 D0 04 0A 0B 0C 78 D0 04 0A 0B 0C

78 D0 04 0A 0B 0C 78 D0 04 0A 0B 0C

78 D0 04 0A 0B 0C 78 D0 04 0A 0B 0C

MISC      CRC

There are some free tools available on Internet that can be used to send a magic packet. Please refer to the following link to understand more about Magic Packet.

<http://en.wikipedia.org/wiki/Wake-on-LAN>

- **Wake on Magic Packet from power off state**

When checking this option, the system can wake from S5 (system off with standby power) state when receiving a magic packet.

### 3.6 Ignition Power Control (IGN Models Only)

The ignition power control module for in-vehicle applications is a MCU-based implementation that monitors the ignition signal and reacts to turn on/off the system according to predefined on/off delay. Its built-in algorithm supports other features such as ultra-low power standby, battery-low protection, system hard-off, etc. In this section, we'll illustrate the principle of ignition power control and operation modes.

#### 3.6.1 Principles of Ignition Power Control

The basic concept of ignition power control module is to control the timing correlation between ignition signal and system power status. A typical timing correlation is described in following diagram.

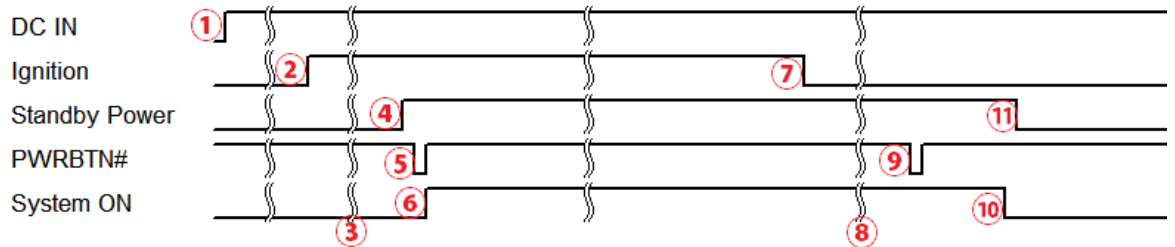

1. When DC power is supplied to the system, MCU starts to periodically detect ignition signal. Note that only MCU is working at this moment and the overall power consumption is less than 2 mW.
2. Ignition signal is active (both 12VDC and 24VDC ignition signals are accepted).
3. MCU starts to count a pre-defined power-on delay.
4. Once power-on delay expired, MCU turns on necessary standby power for the system (3.3VSB & 5VSB).
5. A PWRBTN# pulse is then issued to turn on the system (equivalent to one pressing the power button on the front panel).
6. The system is booting and becomes operational.
7. After a period of time, the ignition signal becomes inactive.
8. MCU starts to count a pre-defined power-off delay.
9. Once power-off delay expired, another PWRBTN# pulse is issued to perform a soft-off for the system (ex. a normal shutdown process for Windows system).
10. The system is completely shut down.
11. As MCU detects system is off, it turns off the standby power for the system, and operates in low power mode again (< 2mW power consumption).

### 3.6.2 Additional Features of Ignition Power Control

In addition to the typical timing correlation, the ignition power control module offers additional features to provide additional reliability for in-vehicle applications.

- **Low battery detection**

The ignition power control module continuously monitors the voltage of DC input when the system is operational. If input voltage is less than 11V (for 12VDC input) or less than 22V (for 20VDC input) over a 60-second duration, it will shut down the system automatically.

- **Guarded power-on/ power-off delay duration**

If ignition signal goes inactive during the power-on delay duration, the ignition power control module will cancel the power-on delay process and go back to idle status. Likewise if ignition signal goes active during the power-off delay duration, the ignition power control module will cancel the power-off delay process and keep the system running.

- **System hard-off**

In some cases, system may fail to shutdown via a soft-off operation due to system/ application halts. The ignition power control module offers a mechanism called “hard-off” to handle this unexpected condition. By detecting the system status, it can determine whether the system is shutting down normally. If not, the ignition power control module will force cut-off the system power 10 minutes after the power-off delay duration.

- **Smart off-delay**

The ignition power control module offers two modes (mode 6 & mode 7) which have very long power-off delay duration for applications require additional off-line time to process after the vehicle has stopped. In these two modes, the ignition power control module will automatically detect the system status during the power-off delay duration. If the system has shutdown (by the application software) prior to power-off delay expiring, it will cut off the system power immediately to prevent further battery consumption.

### 3.6.3 Wiring Ignition Signal

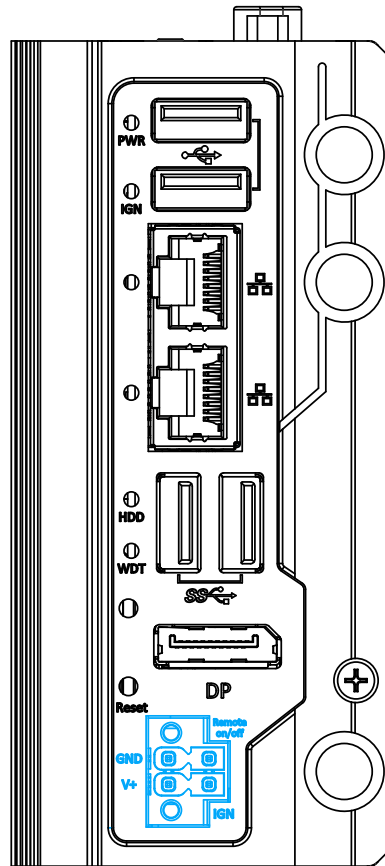

To have ignition power control for in-vehicle usage, you need to supply IGN signal to the system. The IGN input is located on the 4-pin pluggable terminal block (shared with DC power input). For in-vehicle ignition control wiring, please do the following:

1. Connect car Battery+ line to V+.
2. Connect car Batter-/ GND line to GND.
3. Connect ACC line to IGN.



#### WARNING

*Please make sure your DC power source and IGN signal share the same ground. IGN input accepts 12~20VDC. Supply a voltage higher than 20VDC may damage the system.*

### 3.6.4 Configure your Windows system

When applying ignition power control to your system, please make sure you've configured your Windows system to initiate a shutdown process when pressing the power button. By default, Windows 7/ 8/ 10 goes to sleep (S3) mode when power button is pressed. As sleep (S3) is not a complete shutdown behavior, the ignition control function does not recognize the finish of a normal shut down process and thus users will encounter a system hard-off (power cut-off after 10 minutes). Please configure "When I press the power button" to "Shut down" in your Windows system settings.

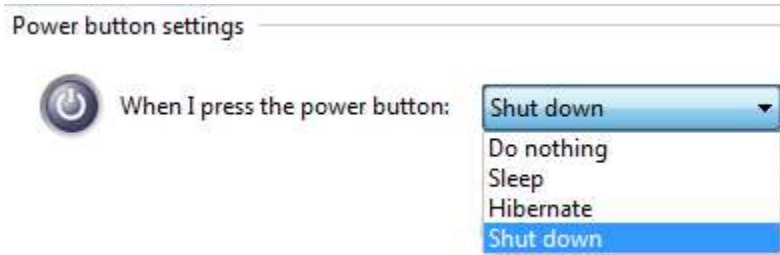



### 3.6.5 Operation Modes of Ignition Power Control

You can use the rotary switch to configure the operation mode. The system offers 16 (0~15) operation modes with different power-on/power-off delay configurations.

The ignition control module is also BIOS-configurable. When rotary switch is set to mode 15 (0xF), the ignition power control is set to executed according to parameters configured in BIOS setup menu, which allows richer combination of power-on/power-off delay and more detailed control parameters.

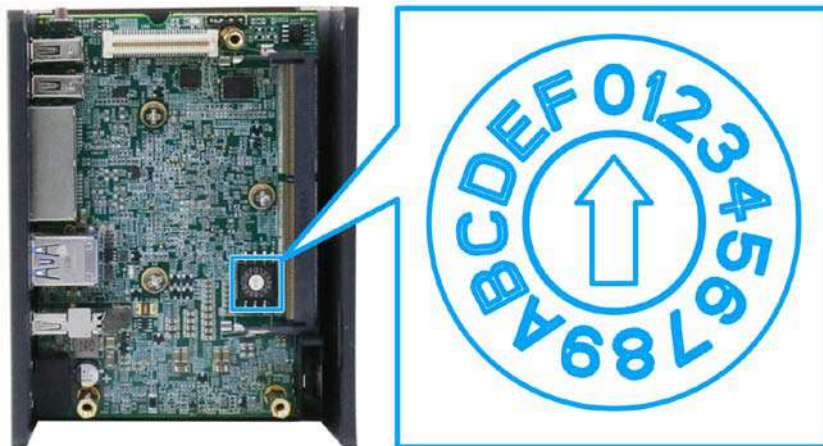

- **Mode 0**

Mode 0 is the ATX mode without power-on and power-off delay. User can only use the power button on the front panel to turn on or turn off the system.

Mode	Power-on Delay	Power-off Delay	Hard-off Timeout
0	N/A	N/A	N/A

- **Mode 1**

Mode 1 is AT mode without power-on and power-off delay. The system automatically turns on when DC power is applied. A retry mechanism is designed to repeat the power-on cycle if the system fails to boot up.

Mode	Power-on Delay	Power-off Delay	Hard-off Timeout
1	N/A	N/A	N/A

- **Mode 2**

Mode 2 is designed to have a very minor power on/ off delay of 160ms for applications that requires the system to start up almost at the same as the rest of the equipment it is working in collaboration with.

Mode	Power-on Delay	Power-off Delay	Hard-off Timeout
2	160ms	160ms	10 minutes

- **Mode 3 ~ Mode 12**

Mode 3 ~ Mode 12 have various power-on delay and power-off delay. Each mode supports a hard-off timeout of 10 minutes.

Mode	Power-on Delay	Power-off Delay	Hard-off Timeout
3	10 seconds	10 seconds	10 minutes
4	10 seconds	1 minute	10 minutes
5	10 seconds	5 minutes	10 minutes
6	30 seconds	1 minute	10 minutes
7	30 seconds	5 minutes	10 minutes
8	30 seconds	10 minutes	10 minutes
9	3 minutes	1 minute	10 minutes
10 (A)	3 minutes	10 minutes	10 minutes
11 (B)	3 minutes	30 minutes	10 minutes
12 (C)	10 minutes	30 minutes	10 minutes

- **Mode 13 (D) / Mode 14 (E)**

Mode 13 and Mode 14 are ignition power control modes with very long power-off delay. Both modes support the feature of “smart off-delay”, which automatically detect system status during power-off delay duration and cut off system power if system is off in prior to power-off delay expired.

Mode	Power-on Delay	Power-off Delay	Hard-off Timeout
13 (D)	30 seconds	2 hours	10 minutes
14 (E)	3 minutes	2 hours	10 minutes

- **Mode 15 (F)**

Mode 15 is reserved for manufacturer purposes.

# 4 BIOS Settings

The system is shipped with factory-default BIOS settings optimized for best performance and compatibility. In this section, we'll illustrate some BIOS settings you may need to set or change prior to operating system installation. Please always make sure you understand the effect of change before you proceed with any changes. If you are unsure of the function you are changing, it is recommended to change one setting at a time to see its effect(s).

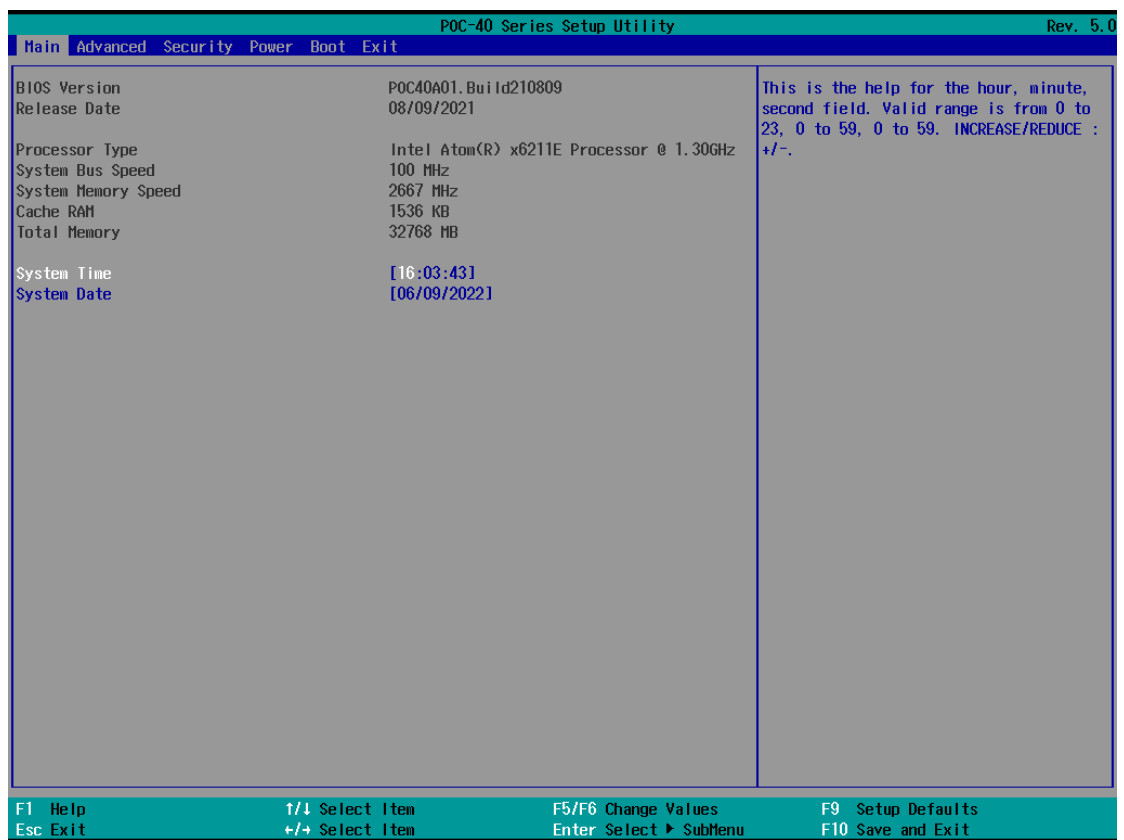

## 4.1 COM1 Port Configuration

The system's [COM1 port](#) supports RS-232 (full-duplex), RS-422 (full-duplex) and RS-485 (half-duplex) mode. You can set the COM1 operating mode via BIOS settings. Another option in BIOS called “*Slew Rate*” defines how sharp the rising/falling edge is for the output signal of COM1. For long-distance RS-422/485 transmission, you may set the “*Slew Rate*” option as “High” to improve signal quality. For RS-422/485 communication, the “*RS-422/485 Termination*” option determines whether to enable/disable internal termination of RS-422/485 transceiver according to your wiring configuration (e.g. with or without external termination).

### To set COM1 operating mode:

1. Press **F2** when the system boots up to enter the BIOS setup utility.
2. Go to **[Advanced]** → **[Peripheral Configuration]**.
3. Set the **[Set COM1 Mode as]** option to the desired mode.
4. Once set, press **F10** to save setting and exit.

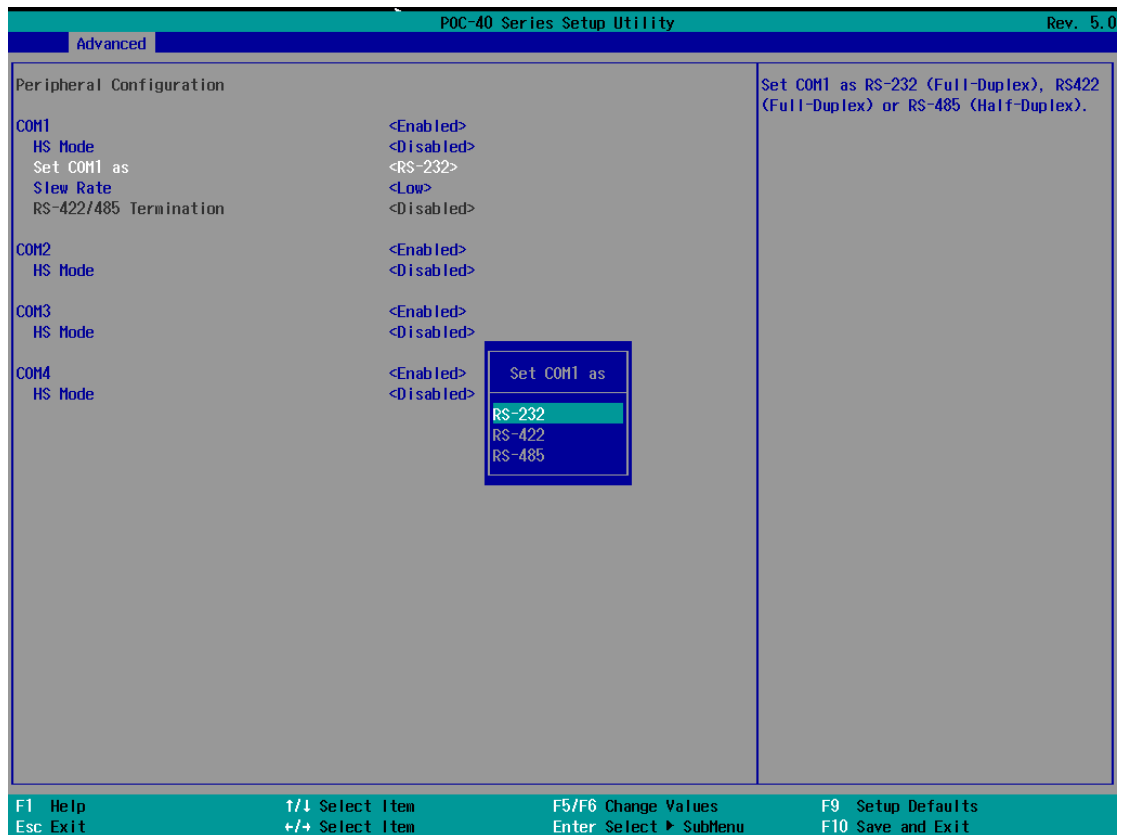

## 4.2 COM2 Port Configuration (POC-40+ Only)

COM2 port also supports RS-422 or RS-485 mode. The operating mode can be configured via the BIOS. For RS-422/485 communication, the “RS-422/485 Termination” option determines whether to enable/disable internal termination of RS-422/485 transceiver according to your wiring configuration (e.g. with or without external termination).

### To set COM2 operating mode:

1. Press **F2** when the system boots up to enter the BIOS setup utility.
2. Go to **[Advanced]** → **[Peripheral Configuration]**.
3. Set the **[Set COM2 as]** option to the desired mode.
4. Once set, press **F10** to save setting and exit.

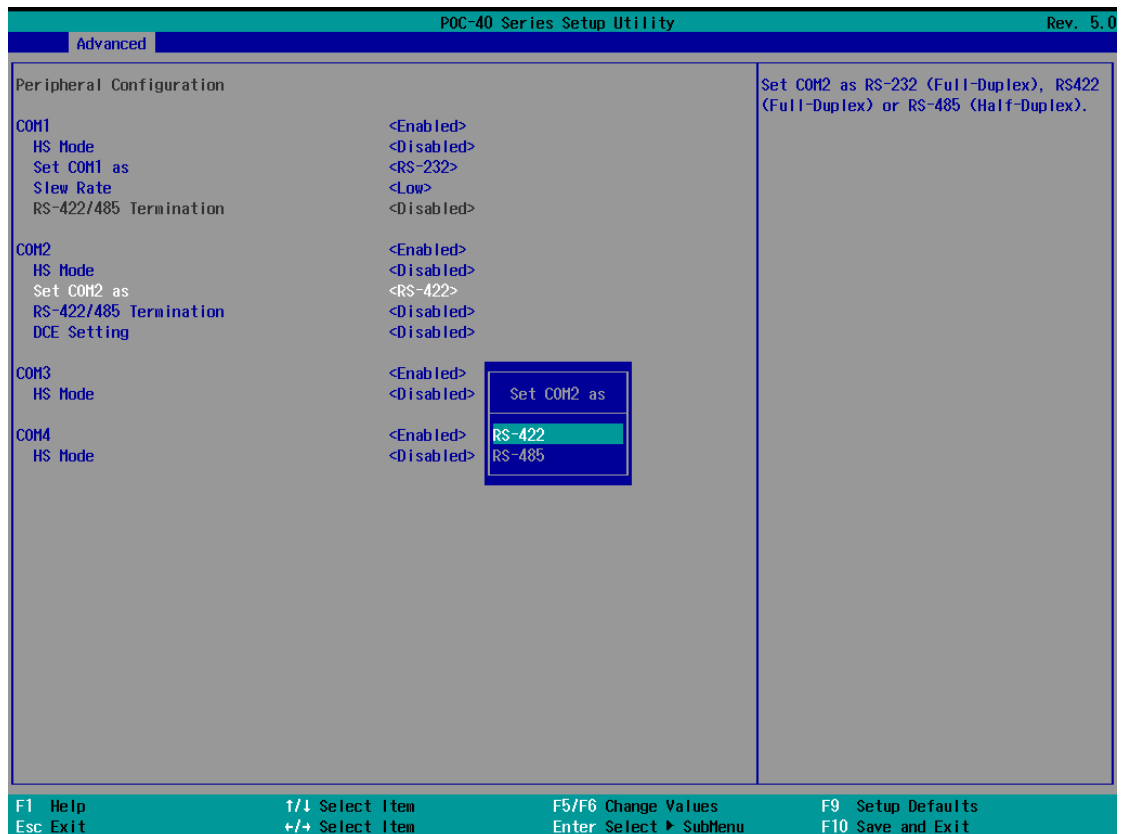

### 4.3 C-States

C-States is a power-saving technique implemented in modern Intel processors. It shuts down the clock signals and power for idle logic units inside the CPU to save the energy consumed. The trade-off, however, is a longer latency for CPU to wake up and be 100% operational. Depending on your application, you can configure these options to have higher performance (disable “C-States”) or lower power-consumption (enable “C-States”).

**To set C-States and Enhanced C-States:**

1. Press **F2** when the system boots up to enter the BIOS setup utility.
2. Go to **[Power] → [CPU Configuration] → [CPU Power Management Control]**
3. Enable/disable the **[C-States]** option according to your application.
4. Once set, press **F10** to save setting and exit.

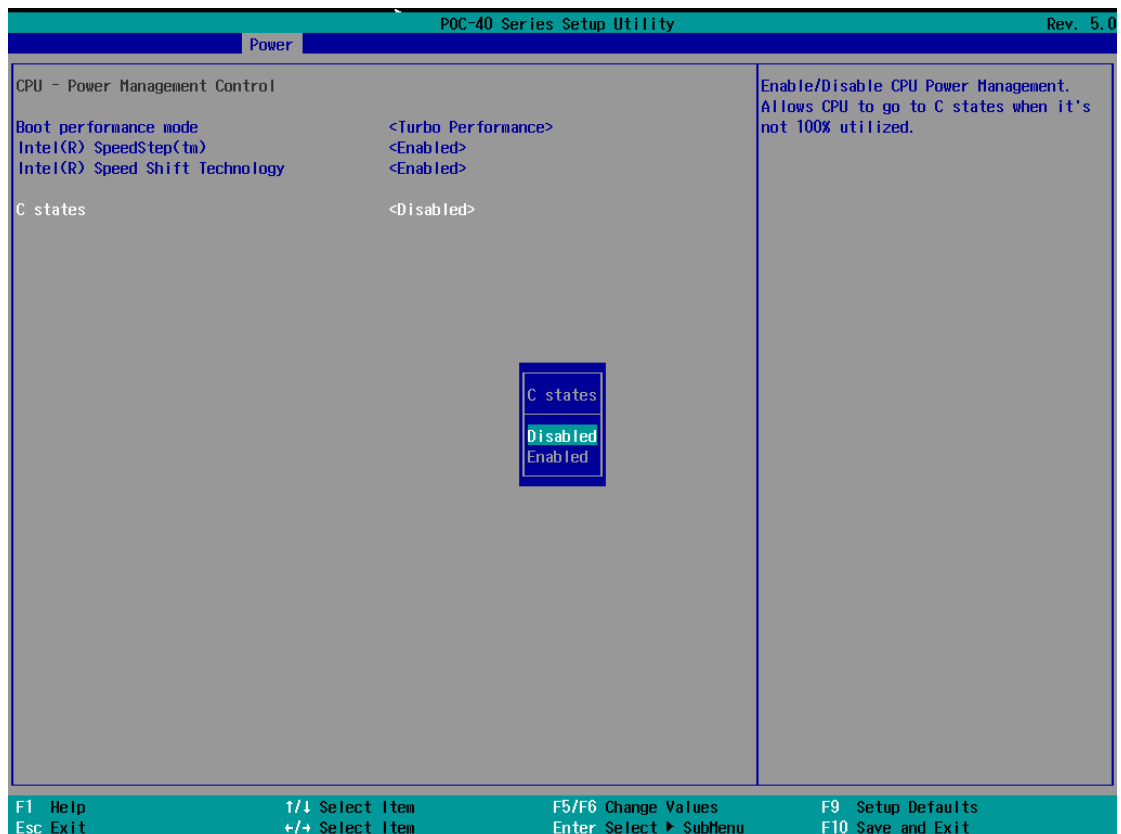

## 4.4 Wake-on-LAN

Wake-on-LAN (WOL) is a mechanism which allows you to turn on your system via Ethernet connection. To utilize Wake-on-LAN function, you have to enable this option first in BIOS settings. Please refer to Powering on via Wake-on-LAN function.

### To enable/disable “Wake on LAN” option:

1. Press **F2** when the system boots up to enter the BIOS setup utility.
2. Go to **[Power]**.
3. You may enable/disable the **[Wake on LAN]** option.
4. Once set, press **F10** to save setting and exit.



## 4.5 Power On after Power Failure

This option defines the system's behavior when DC power is supplied.

Value	Description
S0 – Power On	System is powered on when DC power is supplied.
S5 – Power Off	System is kept in off state when DC power is supplied.

To set “Power On after Power Failure” option:

1. Press **F2** when the system boots up to enter the BIOS setup utility.
2. Go to **[Power]**.
3. Set the **[Power On after Power Failure]** option to the desired setting.
4. Once set, press **F10** to save setting and exit.

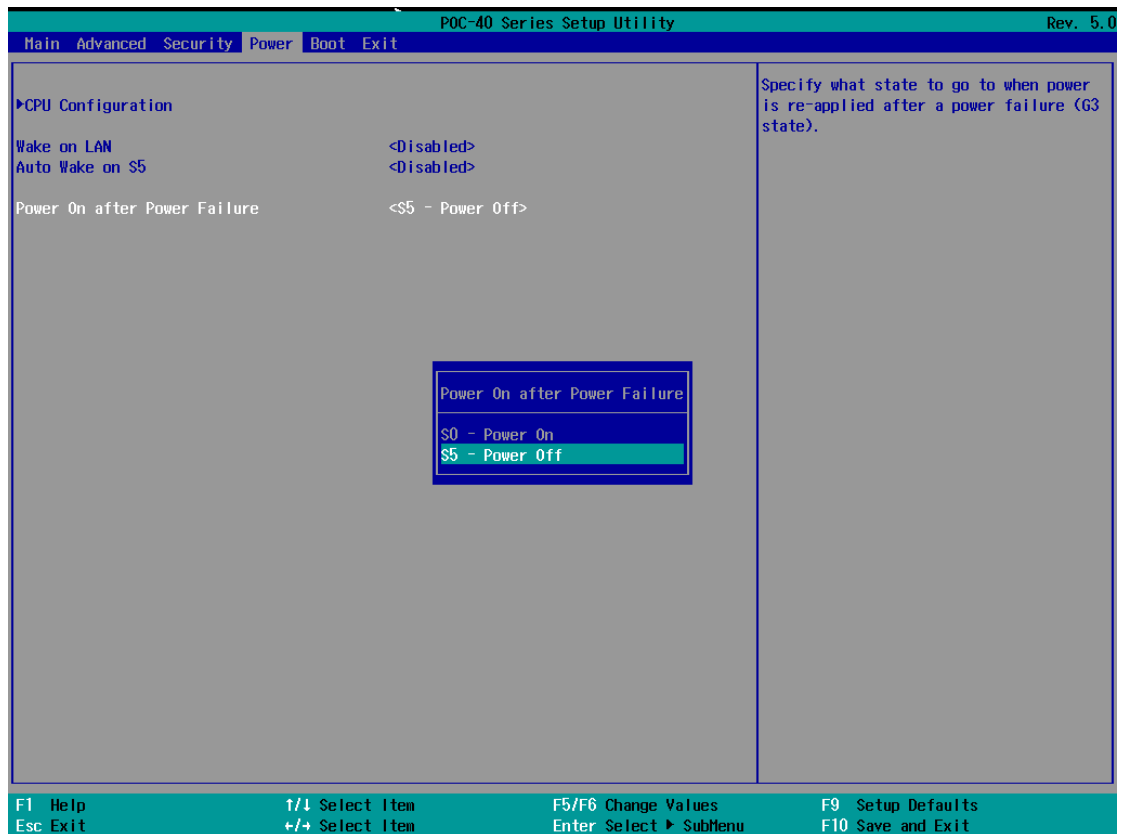



## 4.6 Position New Boot Device

The “Add Boot Options” allow you to determine whether a newly added device (eg. USB flash disk) is to boot as the first device to boot or the last in the boot sequence.

To set the newly-installed boot device as the first or last boot device:

1. Press **F2** when the system boots up to enter the BIOS setup utility.
2. Go to **[Boot] > [Add Boot Options]** menu.
3. Select **[First]**, **[Last]** or **[Auto]** for your newly-added boot device and press Enter.
4. Once set, press **F10** to save setting and exit.

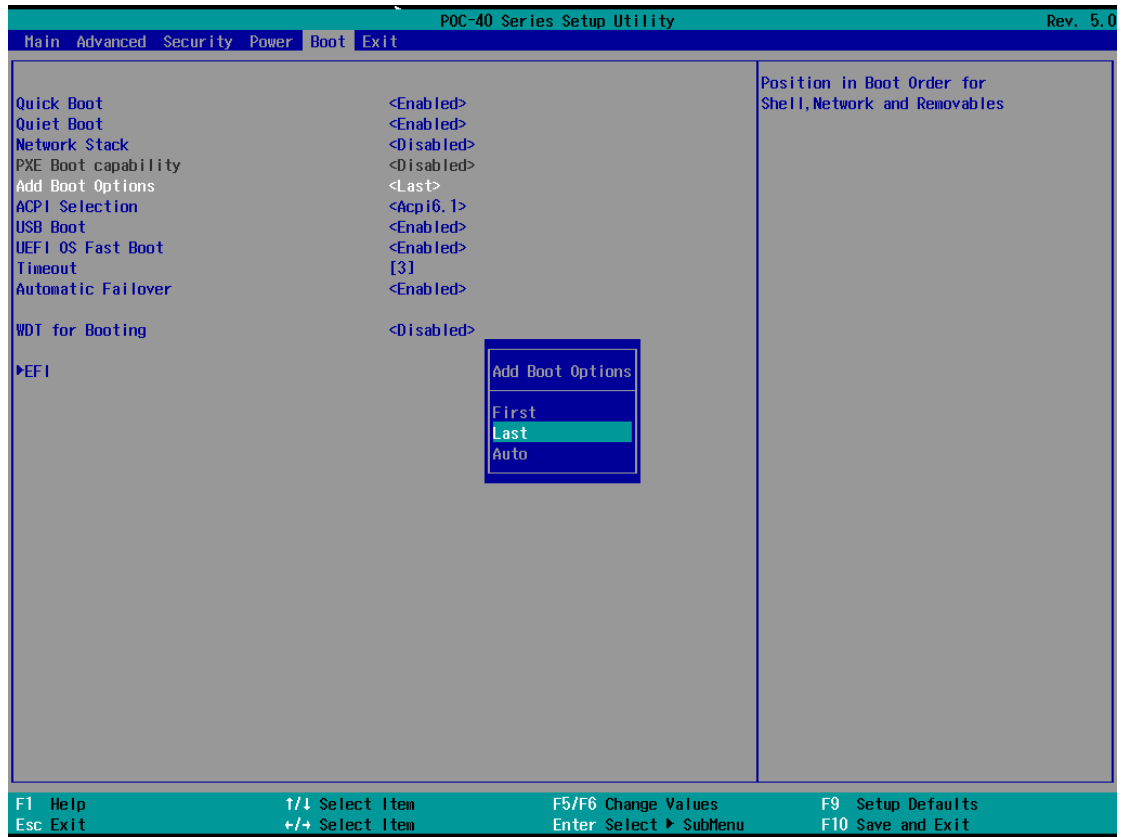

## 4.7 Watchdog Timer

The watchdog timer secures the boot process by means of a timer. Once the timer expires, a reset command is issued to initiate another booting process. There are two options in BIOS menu, “*Automatically after POST*” and “*Manually after Entering OS*”. When “*Automatically after POST*” is selected, the BIOS automatically stops the watchdog timer after POST (Power-On Self Test) OK. When “*Manually after Entering OS*” is selected, the user must stop the watchdog timer once booted into the OS. This guarantees the system can always boot into the OS, otherwise another booting process will be initiated. For information about programming watchdog timer, please refer to [Appendix A Using WDT & DIO](#).

To set the watchdog timer for boot in BIOS:

1. Press **F2** when the system boots up to enter the BIOS setup utility.
2. Go to **[Boot]** menu.
3. Disable or select timeout value for **[WDT for Booting]** option.
4. Once you set a timeout value, the **[WDT Stop Option]** option appears. You can select either “*Automatically after POST*” or “*Manually after Entering OS*”.
5. Once set, press **F10** to save setting and exit.

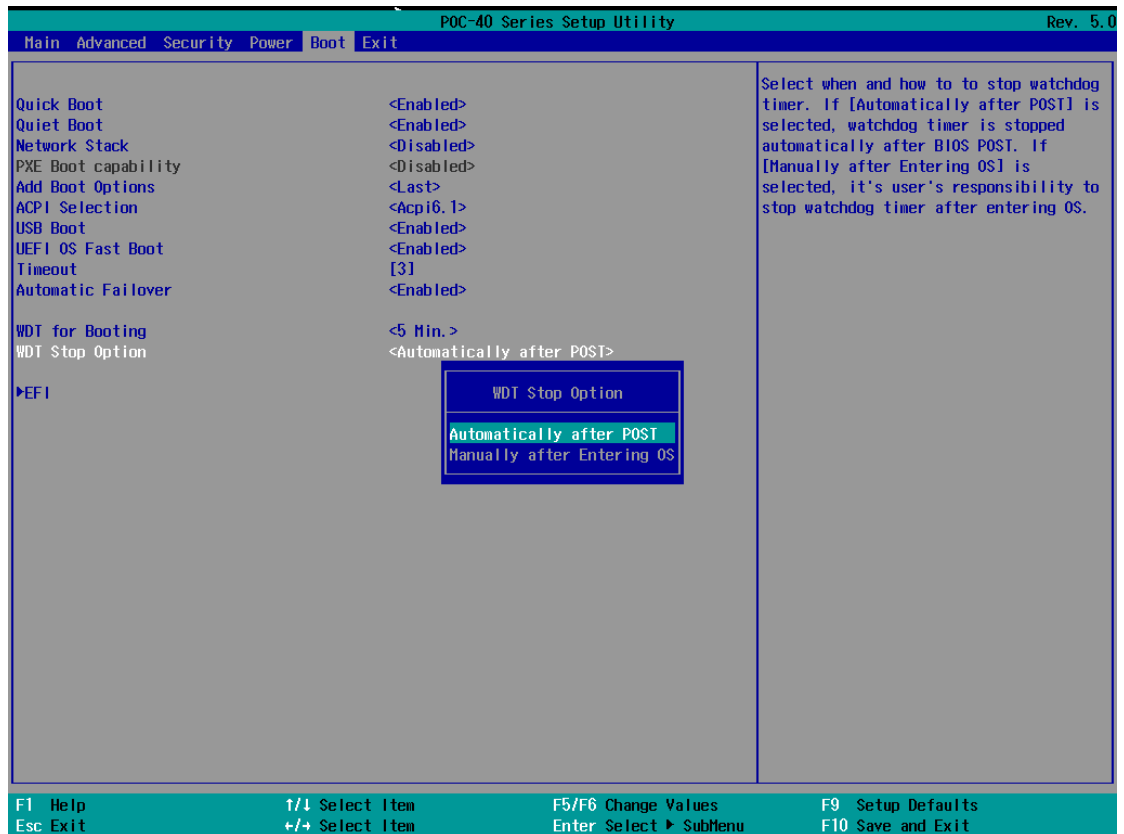

## 5 OS Support and Driver Installation

### 5.1 Operating System Compatibility

Due to Intel's policy, POC-40 series only provide driver support for Windows 10 64-bit. For Linux support, please use Linux kernel versions no later than 4.10. The following list contains the operating systems which have been tested in Neosys Technology Inc.

- Microsoft Windows 10 Professional 64-bit
- Microsoft Windows 10 IoT Enterprise 64-bit
- Ubuntu 20.04.2 LTS\*\* (5.8 kernel)



#### NOTE

*\*For Linux system, user may need to manually compile and install the driver for Intel graphics or I210 GbE controller if the driver is not embedded in kernel. You can visit Intel website for further information.*

Neosys may remove or update operating system compatibility without prior notice. Please contact us if your operating system of choice is not on the list.

## 5.2 Driver Installation

The system comes with a “Drivers & Utilities” DVD that offers “one-click” driver installation process. It automatically detects your Windows operating system and installs all necessary drivers for your system with a single click.

### 5.2.1 Install Drivers Automatically

To install drivers automatically, please refer to the following procedures.

1. Insert the “Drivers & Utilities” DVD into a USB DVD-drive connect to your system. A setup utility launches and the following dialog appears.



2. Click on “**Automatic Driver Installation**” and the setup utility will automatically detect your Windows operating system and install all necessary drivers. The installation process takes about 6~8 minutes depending on your Windows version. Once driver installation is done, the setup utility reboots your Windows and you may begin using your system.

## 5.2.2 Install Drivers Manually

You can also manually install each driver for the system. Please note when installing drivers manually, you need to install the drivers in the following sequence mentioned below.

### Windows 10 (x64)

The recommended driver installation sequence is

1. **Chipset driver** (x:\Driver\_Pool\Chipset\_10\_APL\Win\_ALL\SetupChipset.exe)
2. **Graphics driver**  
(x:\Driver\_Pool\Graphics\_SKL\_APL\Win\_7\_8\_10\_APL\_64\Setup.exe)
3. **LAN driver**  
(x:\Driver\_Pool\GbE\_I210\_I350\Win\_ALL\_64\APPS\PROSETDX\Winx64\DxSet  
etup.exe)
4. **TXE driver** (x:\Driver\_Pool\TXE\_APL\Win\_10\_64\SetupTXE.exe)

## 5.3 Driver for Watchdog Timer and DIO

Neosys provides a driver package which contains function APIs for WDT functions. You should install the driver package (WDT\_DIO\_Setup.exe) in prior to use these functions. Please note that you must install WDT\_DIO\_Setup\_v2.3.1 or later versions.



### NOTE

Please install WDT\_DIO\_Setup\_v2.3.1 or later versions.

#### **Windows 7/ 8/ 10 (x64)**

Please execute the driver setup program in the following directory.

x:\Driver\_Pool\WDT\_DIO\Win7\_8\_10\_64\WDT\_DIO\_Setup\_v2.3.1(x64).exe

#### **Windows 7/ 8/ 10 (WOW64)**

Please execute the driver setup program in the following directory.

x:\Driver\_Pool\WDT\_DIO\Win7\_8\_10\_WOW64\WDT\_DIO\_Setup\_v2.3.1(wow64).exe

# Appendix A Using WDT & DIO

The watchdog timer (WDT) function to ensure reliable system operation. The WDT is a hardware mechanism to reset the system if the watchdog timer is expired. Users can start the WDT and keeping resetting the timer to make sure the system or program is running. Otherwise, the system shall be reset.

In this section, we'll illustrate how to use the function library provided by Neosys to program the WDT functions. Currently, WDT driver library supports Windows 10 x64 and WOW64 platform. For other OS support, please contact Neosys Technology for further information.

## Installing WDT\_DIO Library

The WDT\_DIO function library is delivered in the form of a setup package named **WDT\_DIO\_Setup.exe**. In prior to program WDT, you should execute the setup program and install the WDT library. Please use the following WDT\_DIO\_Setup packages according to your operating systems and application.

- For Windows 10 64-bit OS with 64-bit application (x64 mode), please install WDT\_DIO\_Setup\_v2.3.1(x64).exe or later version.
- For Windows 10 64-bit OS with 32-bit application (WOW64 mode), please install WDT\_DIO\_Setup\_v2.3.1(wow64).exe or later version.

## WDT and DIO Library Installation

To setup WDT & DIO Library, please follow instructions below.

1. Execute **WDT\_DIO\_Setup.2.3.1.exe**. and the following dialog appears.

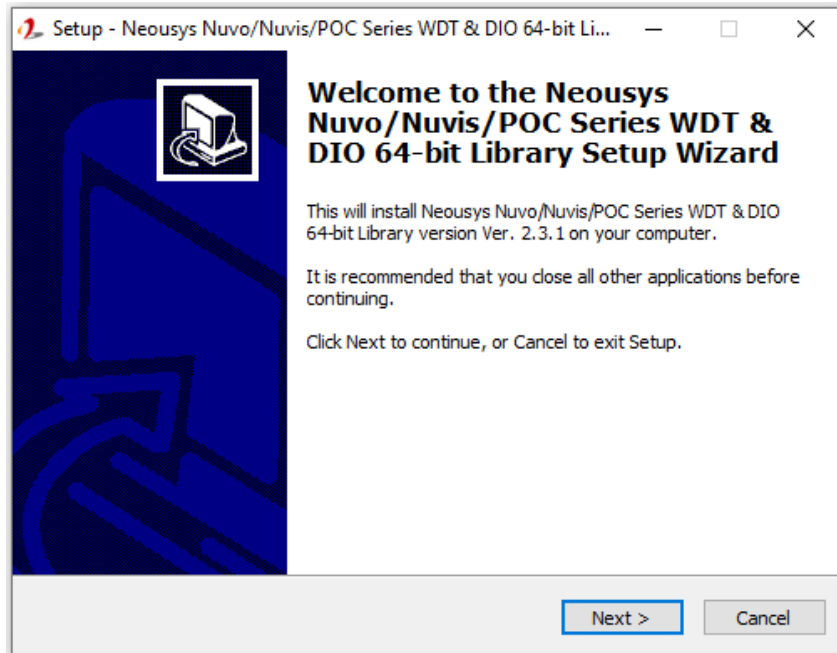

2. Click "Next >" and specify the directory of installing related files. The default directory is *C:\Neosys\WDT\_DIO*.

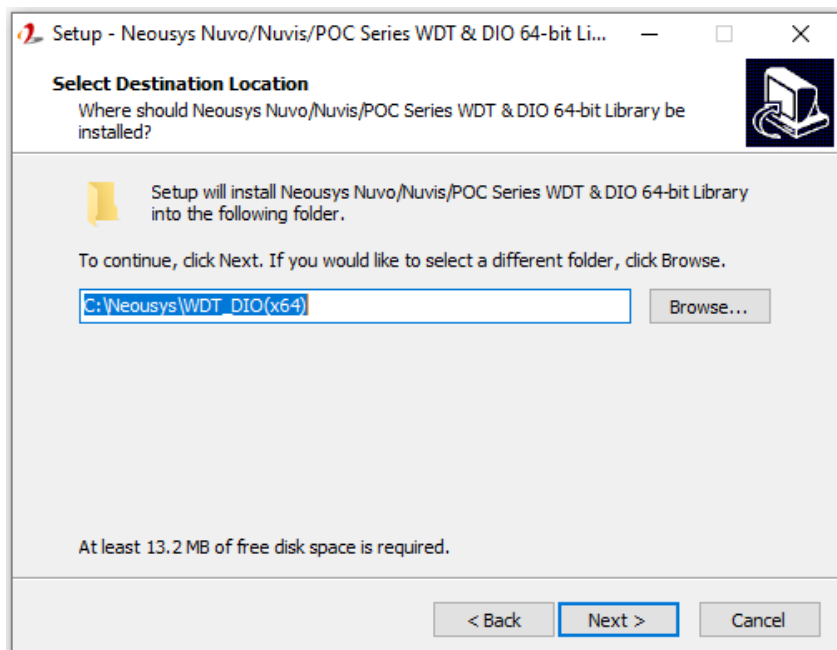



- Once the installation has finished, a dialog will appear to prompt you to reboot the system. The WDT & DIO library will take effect after the system has rebooted.

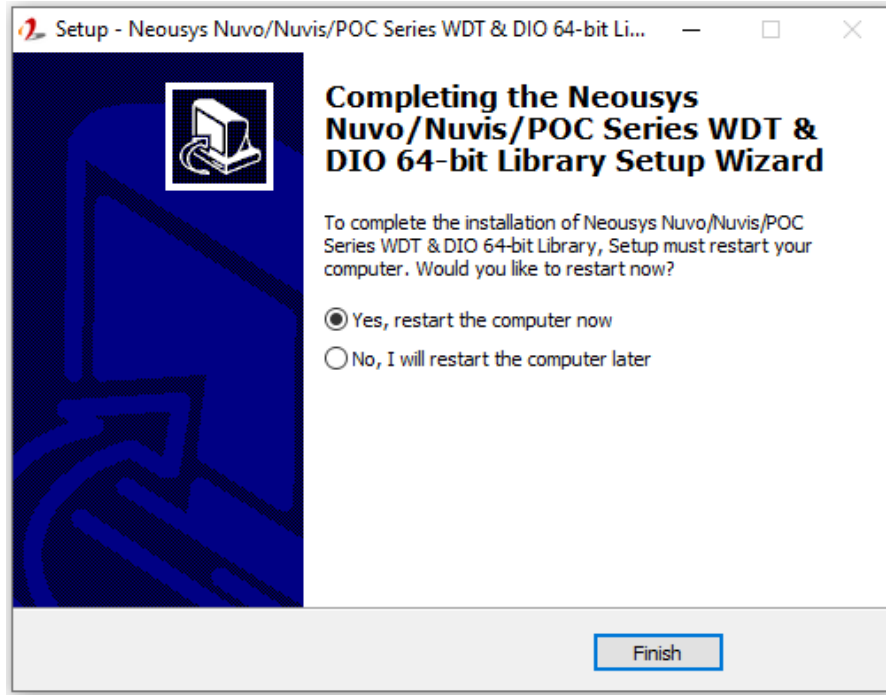

- When programming your WDT or DIO program, the related files are located in

<b>Header File:</b>	\Include
<b>Library File:</b>	\Lib
<b>Function Reference:</b>	\Manual
<b>Sample Code:</b>	\Sample\WDT_Demo (Demo for Watchdog Timer) \Sample\DIO_Demo (Demo for isolated DIO Control) \Sample\COS_Demo (Demo for change-of-state DI)

□□

## WDT Function Reference

### InitWDT

<b>Syntax</b>	BOOL InitWDT(void);
<b>Description:</b>	Initialize the WDT function. You should always invoke InitWDT() before set or start watchdog timer.
<b>Parameter</b>	None
<b>Return Value</b>	<b>TRUE:</b> Successfully initialized <b>FALSE:</b> Failed to initialize
<b>Usage</b>	BOOL    bRet = InitWDT()

### SetWDT

<b>Syntax</b>	BOOL SetWDT(WORD tick, BYTE unit);
<b>Description</b>	Set timeout value and unit for watchdog timer. When InitWDT() is invoked, a default timeout value of 255 seconds is assigned.
<b>Parameter</b>	<i>tick</i> WORD value (1 ~ 65535) to indicate timeout ticks. <i>unit</i> BYTE value (0 or 1) to indicate unit of timeout ticks. 0 : unit is minute 1 : unit is second
<b>Return Value</b>	If value of unit is correct (0 or 1), this function returns TRUE, otherwise FALSE.
<b>Usage</b>	WORD    tick=255; BYTE    unit=1; //unit is second. BOOL    bRet = SetWDT(tick, unit); //timeout value is 255 seconds

### StartWDT

<b>Syntax</b>	BOOL StartWDT(void);
<b>Description</b>	Starts WDT countdown. Once started, the WDT LED indicator will begin blinking. If ResetWDT() or StopWDT is not invoked before WDT countdowns to 0, the WDT expires and the system resets.
<b>Parameter</b>	None
<b>Return Value</b>	If the timeout value is given in correct format (WDT started), this function returns TRUE, otherwise FALSE
<b>Usage</b>	BOOL bRet = StartWDT();

### ResetWDT

<b>Syntax</b>	BOOL ResetWDT(void);
<b>Description</b>	Reset the timeout value to the value given by SetWDT().If ResetWDT() or StopWDT is not invoked before WDT countdowns to 0, the WDT expires and the system resets.
<b>Parameter</b>	None
<b>Return Value</b>	Always returns TRUE
<b>Usage</b>	BOOL bRet = ResetWDT();

### StopWDT

<b>Syntax</b>	BOOL StopWDT(void);
<b>Description</b>	Stops the countdown of WDT. When WDT has stopped, the WDT LED indicator stops blinking.
<b>Parameter</b>	None
<b>Return Value</b>	Always returns TRUE
<b>Usage</b>	BOOL bRet = StopWDT();