

User Manual

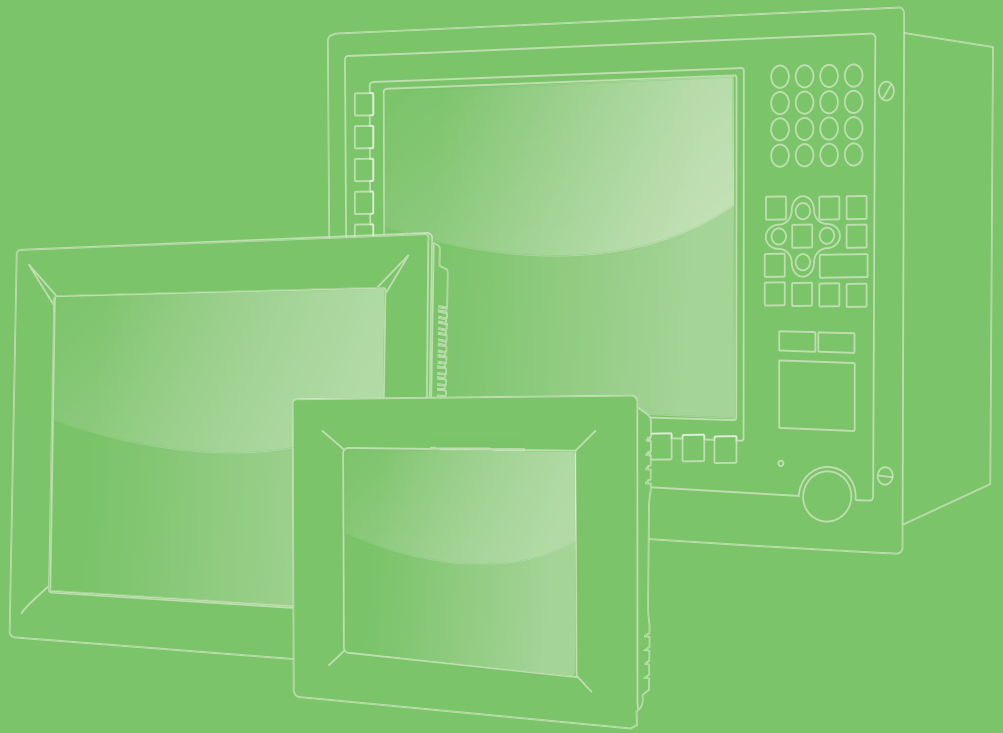

PPC-3100-RE9A PPC-3120-RE9A

10.4"/12.1" Color TFT LCD Panel PC
with Intel® Atom™ E3940 Processor

ADVANTECH

Enabling an Intelligent Planet

Copyright

The documentation and the software included with this product are copyrighted 2019 by Advantech Co., Ltd. All rights are reserved. Advantech Co., Ltd. reserves the right to make improvements to the products described in this manual at any time without notice. No part of this manual may be reproduced, copied, translated, or transmitted in any form or by any means without the prior written permission of Advantech Co., Ltd. The information provided in this manual is intended to be accurate and reliable. However, Advantech Co., Ltd. assumes no responsibility for its use, nor for any infringements of the rights of third parties that may result from its use.

Acknowledgements

Intel and Celeron are trademarks of Intel Corporation.

Microsoft Windows is registered trademark of Microsoft Corp.

All other product names or trademarks are properties of their respective owners.

Product Warranty (2 years)

Advantech warrants the original purchaser that its products will be free from defects in materials and workmanship for two years from the date of purchase.

This warranty does not apply to any products that have been repaired or altered by persons other than repair personnel authorized by Advantech, or products that have been subject to misuse, abuse, accident, or improper installation. Advantech assumes no liability under the terms of this warranty as a consequence of such events.

Because of Advantech's high quality-control standards and rigorous testing, most customers never need to use our repair service. However, if an Advantech product is defective, it will be repaired or replaced free of charge during the warranty period. For out-of-warranty repairs, customers are billed according to the cost of replacement materials, service time, and freight. Please consult your dealer for more details.

If you believe your product to be defective, follow the steps outlined below.

1. Collect all the information about the problem encountered. (For example, CPU speed, Advantech products used, other hardware and software used, etc.) Note anything abnormal and list any onscreen messages displayed when the problem occurs.
2. Call your dealer and describe the problem. Please have your manual, product, and any relevant information readily available.
3. If your product is diagnosed as defective, obtain a return merchandise authorization (RMA) number from your dealer. This allows us to process your return more quickly.
4. Carefully pack the defective product, a completed Repair and Replacement Order Card, and proof of purchase date (such as a photocopy of your sales receipt) into a shippable container. Products returned without a proof of purchase date are not eligible for warranty service.
5. Write the RMA number on the outside, and ship the package prepaid to your dealer.

Declaration of Conformity

CE

This product has passed the CE test for environmental specifications. Test conditions for passing included the equipment being operated within an industrial enclosure. In order to protect the product from damage resulting from electrostatic discharge (ESD) or electromagnetic interference (EMI) leakage, we strongly recommend using CE-compliant industrial enclosure products.

Technical Support and Assistance

1. Visit the Advantech website at <http://support.advantech.com> to obtain the latest product information.
2. Contact your distributor, sales representative, or Advantech's customer service center for technical support if you need additional assistance. Please have the following information to hand before calling:
 - Product name and serial number
 - Description of your peripheral attachments
 - Description of your software (operating system, version, application software, etc.)
 - A complete description of the problem
 - The exact wording of any error messages

Safety Instructions

1. Read these safety instructions carefully.
2. Retain this user manual for future reference.
3. Disconnect the equipment from all power outlets before cleaning. Use only a damp cloth for cleaning. Do not use liquid or spray detergents.
4. For pluggable equipment, the power outlet socket must be located near the equipment and easily accessible.
5. Protect the equipment from humidity.
6. Place the equipment on a reliable surface during installation. Dropping or letting the equipment fall may cause damage.
7. The openings on the enclosure are for air convection. Protect the equipment from overheating. Do not cover the openings.
8. Ensure that the voltage of the power source is correct before connecting the equipment to a power outlet. The power outlet socket should be grounded.
9. Position the power cord away from high-traffic areas. Do not place anything over the power cord.
10. All cautions and warnings on the equipment should be noted.
11. If the equipment is not used for a long time, disconnect it from the power source to avoid damage from transient overvoltage.
12. Never pour liquid into an opening. This may cause fire or electrical shock.
13. Never open the equipment. For safety reasons, the equipment should be opened only by qualified service personnel.
14. If the following occurs, have the equipment checked by service personnel:
 - The power cord or plug is damaged.
 - Liquid has penetrated into the equipment.
 - The equipment has been exposed to moisture.
 - The equipment is malfunctioning or does not operate according to the user manual.
 - The equipment has been dropped and damaged.
 - The equipment has obvious signs of breakage.
15. Do not leave the equipment in an environment with a storage temperature of below $-40\text{ }^{\circ}\text{C}$ ($-40\text{ }^{\circ}\text{F}$) or above $60\text{ }^{\circ}\text{C}$ ($140\text{ }^{\circ}\text{F}$) as this may cause damage. The equipment should be stored in a controlled environment.
16. CAUTION: Batteries are at risk of exploding if incorrectly replaced. Replace only with the equivalent type recommended by the manufacturer. Discard used batteries according to the manufacturer's instructions.
ATTENTION: Il y a danger d'explosion s'il y a un remplacement incorrect de la pile. Remplacer uniquement avec une pile du même type ou d'un type équivalent recommandé par le constructeur.
17. The equipment should only be installed in a Restricted Access Area.
18. In accordance with IEC 704-1:1982 specifications, the sound pressure level at the operator's position does not exceed 70 dB (A).
19. This product is intended to be supplied by a listed power adapter or DC power source rated $9\text{ } \sim\text{ } 32\text{ V}_{\text{DC}}$, $7\text{ } \sim\text{ } 2\text{ A}$, and TMA $60\text{ }^{\circ}\text{C}$ for PPC-3100-RE9A, and $9\text{ } \sim\text{ } 32\text{ V}_{\text{DC}}$, $8.5\text{ } \sim\text{ } 2.5\text{ A}$, 80W minimum, and TMA $60\text{ }^{\circ}\text{C}$ for C PPC-3120-RE9A. (If you need further information, please contact Advantech.)
20. CAUTION: This product is not intended for use by children and is not suitable for use in locations where children are likely to be present (this product is not a toy). ATTENTION: Ce produit n'est pas un jouet et devrait être gardé hors de la portée des enfants.

21. **DISCLAIMER:** These instructions are provided in accordance with IEC 704-1 standards. Advantech disclaims all responsibility for the accuracy of any statements contained herein.

Safety Precautions - Static Electricity

Follow the simple precautions below to protect yourself from harm and the products from damage.

- To avoid electrical shock, always disconnect the power from the PC chassis before manual handling. Do not touch any components on the CPU card or other cards while the equipment is powered on.
- Disconnect the power before executing any configuration changes. A sudden rush of power after connecting a jumper or installing a card may damage sensitive electronic components.

Battery Information

Batteries, battery packs, and accumulators should not be disposed of as unsorted household waste. Please use the public collection system to return, recycle, or treat them in compliance with local regulations.



Manual Conventions

Warning! Warnings indicate conditions that if not observed can cause personal injury!



Caution! Cautions are included to prevent hardware damage and data loss.



For example, “Batteries are at risk of exploding if replaced with an incorrect type. Replace only with the same or equivalent type recommended by the manufacturer. Dispose of used batteries according to the manufacturer’s instructions.”

Par exemple, “Si la batterie est remplacée par un modèle inapproprié, il y a un risque d’explosion. Remplacer les produits identiques ou équivalents recommandés par le fabricant. Traitement des piles usagées selon les instructions du fabricant.”

Note! Notes provide additional optional information.



Revision

| Date | Version | Description/Change |
|---------------|----------------|---------------------------|
| July 2018 | 1.0 | Initial |
| December 2018 | 1.1 | Edition 2 |

Contents

| | | |
|------------------|---|-----------|
| Chapter 1 | General Information | 1 |
| 1.1 | Introduction | 2 |
| 1.2 | Key Features..... | 2 |
| 1.3 | Front Panel..... | 2 |
| | Figure 1.1 Front Panel..... | 2 |
| 1.4 | Rear Panel | 3 |
| | Figure 1.2 Rear Panel..... | 3 |
| 1.5 | Dimensions | 3 |
| | Figure 1.3 PPC-3100-RE9A Dimensions..... | 3 |
| | Figure 1.4 PPC-3120-RE9A Dimensions..... | 4 |
| 1.6 | Specifications | 4 |
| 1.7 | Ordering Information | 5 |
| | | |
| Chapter 2 | System Installation and Setup | 7 |
| 2.1 | Quick System Tour..... | 8 |
| | Figure 2.1 Panel PC Front View | 8 |
| | Figure 2.2 Panel PC Rear View..... | 8 |
| | Figure 2.3 Panel PC I/O Ports | 9 |
| 2.2 | Installation Procedures..... | 9 |
| | 2.2.1 HDD Installation | 9 |
| | 2.2.2 mSATA Installation | 15 |
| | 2.2.3 Memory Card Installation | 15 |
| | 2.2.4 Wireless LAN Module Installation | 17 |
| | 2.2.5 Expansion Kit Installation (for PPC-3120-XE9 only)..... | 19 |
| 2.3 | Mounting the System | 21 |
| | 2.3.1 Wall Mounting | 21 |
| | 2.3.2 Panel Mounting..... | 23 |
| | 2.3.3 Arm Mounting..... | 25 |
| | 2.3.4 Stand Mounting..... | 26 |
| | | |
| Chapter 3 | Jumper Settings | 29 |
| 3.1 | Motherboard Layout..... | 30 |
| 3.2 | Jumper and Connector Settings..... | 31 |
| 3.3 | External COM Ports Pin Definition | 33 |
| | 3.3.1 COM1 ~ COM5: RS232 | 33 |
| | 3.3.2 COM3: RS-422/485 with Isolation..... | 34 |
| | 3.3.3 Change COM4 to DIO..... | 34 |
| | | |
| Chapter 4 | Software Setup | 37 |
| 4.1 | Driver Installation | 38 |
| 4.2 | BIOS Setup Program | 38 |
| | 4.2.1 Entering BIOS Setup..... | 38 |
| | 4.2.2 Adjustment of LCD Brightness..... | 39 |
| | 4.2.3 COM2 Mode Selection (RS232/RS422/RS485) | 41 |
| | 4.2.4 OS Selection | 43 |
| | 4.2.5 BIOS AT and ATX Setup | 44 |
| | 4.2.6 Wake-on-LAN | 46 |

Appendix A **Watchdog Timer Programming 49**

| | | |
|-----|--|----|
| A.1 | Watchdog Timer Programming Example | 50 |
|-----|--|----|

Chapter 1

General Information

- Introduction
- Specifications
- Dimensions

1.1 Introduction

Advantech's PPC-3100/3120-RE9A is an all-in-one lightweight panel PC equipped with a 10.4"/12.1" TFT LCD. Powered by an Intel® Atom™ E3940 processor, PPC-3100/3120-RE9A provides excellent performance, memory, graphics, and peripheral I/O support in a compact, fanless, embedded system. Built for high durability, PPC-3100/3120-RE9A features a flat touchscreen with IP65 ingress protection and die-cast aluminum alloy enclosure. It's ideal for easy and simple integration into various applications.

1.2 Key Features

- Robust IP65-rated true-flat color TFT LCD
- Ultra-thin fanless design with aluminum alloy front bezel
- Intel® Atom™ E3940 processor
- 1 x SODIMM DDR3L 1866 MHz (max. 8 GB)
- 1 x Full-size mini PCIe card slot
- 4 x USB 3.0 ports
- Supports SATA 6 Gb/s interface for 2.5" SATA storage
- Optional mini PCIe 802.11b/g/n wireless module

1.3 Front Panel

The PPC-3100/3120-RE9A front panel is a true-flat color TFT LCD with resistive touch control and an IP65 rating for resistance to dust and water (Figure 1.1).

Note! *Figure 1.1 shows the PPC-3100-RE9A model. The PPC-3100/3120-XE9X model features the same design.*



Figure 1.1 Front Panel

1.4 Rear Panel

The PPC-3100/3120-RE9A rear panel features four VESA mount holes (75 x 75 mm), as shown in Figure 1.2.

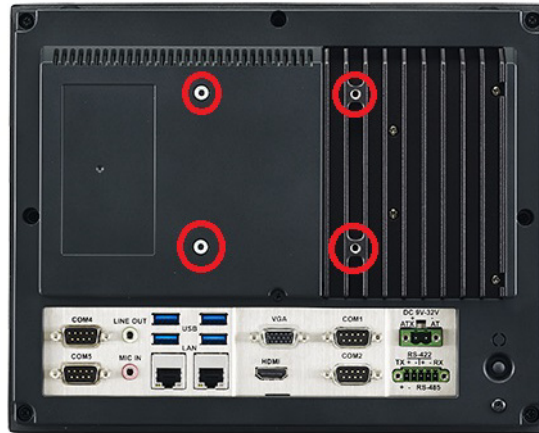
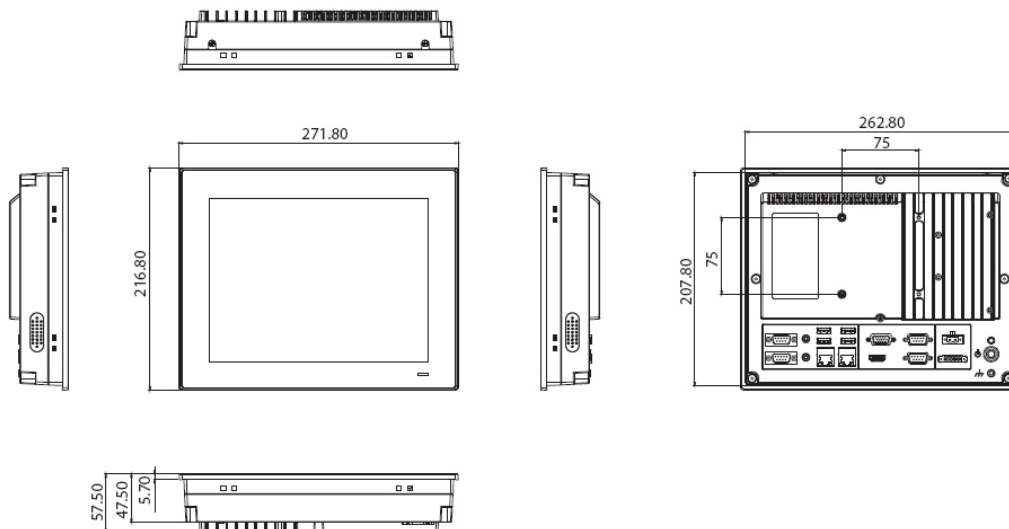

Figure 1.2 Rear Panel

1.5 Dimensions

Unit: mm



Panel Cutout Dimensions: 265 x 210 mm (10.43 x 8.26 in)

Figure 1.3 PPC-3100-RE9A Dimensions

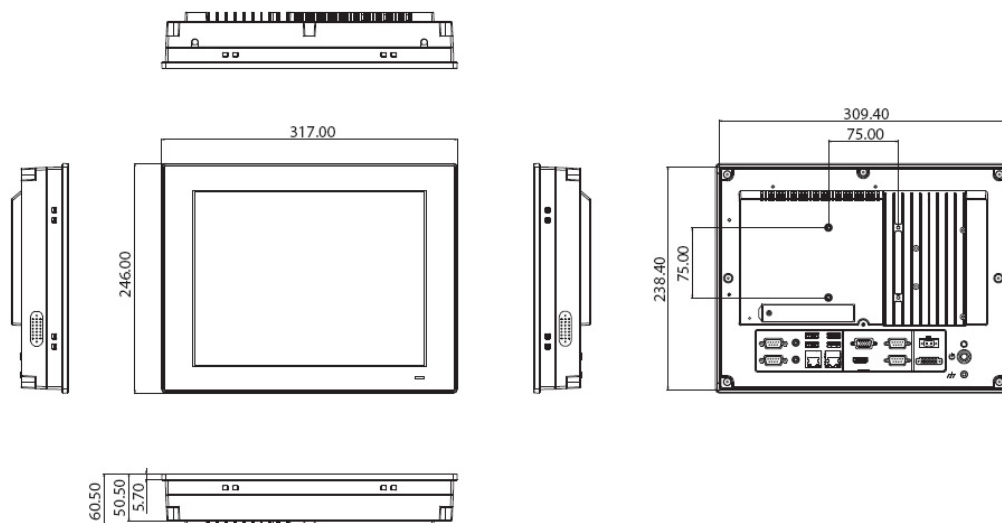

Panel Cutout Dimensions: 311 x 240 mm (12.24 x 9.44 in)

Figure 1.4 PPC-3120-RE9A Dimensions

1.6 Specifications

| | PPC-3100-RE9A | PPC-3120-RE9A |
|--------------------|---|-----------------------|
| LCD Panel | 10.4" | 12.1" |
| Display Type | TFT LCD | TFT LCD |
| Max. Resolution | 800 x 600 | 1024 x 768 |
| Brightness | 400 | 600 |
| Color | 262k/16.2M | 262k/16.2M |
| Pixel Pitch | 0.264 (H) x 0.264 (V) | 0.240 (H) x 0.240 (V) |
| Viewing Angle | 160, 140 | 160, 140 |
| Contrast | 5000 | 700 |
| Backlight Lifetime | 30,000 hrs (minimum) | 50,000 hrs (minimum) |
| Touchscreen Type | 5-wire resistive touch | |
| Light Transmission | 80±5% | |
| Controller | USB interface | |
| Durability | At least 35 million touches without failure | |
| CPU | Intel® Atom™ E3940 quad-core | |
| Memory | 1 x SODIMM DDR3L 1866 MHz (max. 8 GB) | |
| Storage | 1 x 2.5" SATA bay 1 x mSATA bay | |
| Network (LAN) | 2 x 10/100/1000 Mbps Ethernet | |
| I/O | 5 x Serial ports: 4 x RS-232 and 1 x isolated RS-422/485 (configurable via the BIOS system) 4 x USB 3.0 1 x Line-out, 1 x Mic-in 1 x VGA 1 x HDMI 1 x GPIO (8 channels, TTL level, internal) | |
| Expansion | 1 x Mini PCIe Optional: 1 x PCIe x1 or 1 x PCI (for PPC-3120) | |

| | | |
|-----------------------|--|--|
| Speaker | 2 x 1W | |
| OS Support | Microsoft® Windows 10 IoT Enterprise, Linux, Android 6.0 Marshmallow | |
| Power Supply | 9 ~ 32 VDC | |
| Power Consumption | 30 W | 32 W |
| Operating Temperature | 0 ~ 50 °C (32 ~ 122 °F) with 2.5" SATA SSD -20 ~ 60 °C (-4 ~ 140 °F) with -40 ~ 85 °C (-40 ~ 185 °F) mSATA or 2.5" SATA SSD | |
| Storage Temperature | -30 ~ 60 °C (-22 ~ 140 °F) | -40 ~ 60 °C (-40 ~ 140 °F) |
| Relative Humidity | 10 ~ 95% @ 40 °C (non-condensing) | |
| Shock | Operating 10G peak acceleration (11ms duration), following IEC 60068-2-27 | |
| Vibration | Operating random vibration test, 5 ~ 500 Hz, 1 Grms with HDD; 2 Grms with SSD, following IEC 60068-2-64 | |
| Safety and EMC | Safety: CB, UL, CCC, BSMI EMC: CE, FCC Class B, BSMI | |
| Dimensions | 271.8 x 216.8 x 57.5 mm (10.7 x 8.5 x 2.3 in) | 317 x 246 x 60.5 mm (12.5 x 9.7 x 2.4 in) |
| Weight | 2.8 kg (6.17 lb) | 3.4 kg (7.5 lb) |

Note! The test conditions for the power consumption values provided above were as follows:







OS: Windows 10 (64 bit)

Software: Burn-In (8.0)

Ports: 4 x loopback COM port (RS232), 3 x USB 3.0 device, 1 x USB mouse

1.7 Ordering Information

| Part Number | Description | Image |
|--------------------------------|---|---|
| PPC-3100-RE9A PPC-3120-RE9A | Panel PC with Intel® Atom™ E3940 processor |  |
| 98R3P30610E | PPC-3120 add-on box for PCI or PCIe expansion kit |  |
| 96PSA-A90W19OT-3 | Power adapter 100 ~ 240 VDC, 90 W, 19V with PFC |  |
| PPC-WLAN-C1E | Wi-Fi module with antenna |  |

PPC-ARM-A03

Arm mount VESA standard



PPC-174T-WL-MTE

Wall mount kit

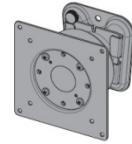

PPC-Stand-A1E

Stand kit

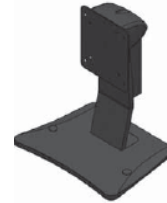

Chapter 2

System Installation and Setup

- Quick System Tour
- Memory Card Installation
- HDD Installation
- mSATA Installation
- Wireless LAN Card Installation
- Expansion Kit Installation
- Mounting the System

2.1 Quick System Tour

Before setting up the panel PC, take a moment to identify the locations of the device controls, drives, connectors, and ports (as shown in Figure 2.3). When placed upright, the PPC-3100/3120-RE9A front panel should appear as shown in Figure 2.1.



Figure 2.1 Panel PC Front View



Figure 2.2 Panel PC Rear View

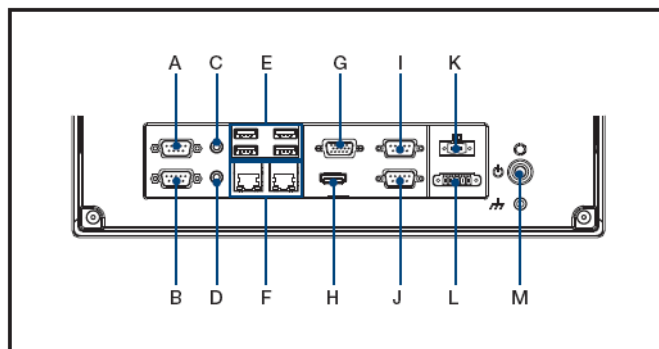

| | |
|-----------------|-------------------------------|
| A. COM4: RS-232 | H. HDMI |
| B. COM5: RS-232 | I. COM1: RS-232 |
| C. Line Out | J. COM2: RS-232 |
| D. Mic In | K. DC Inlet and AT/ATX switch |
| E. 4 x USB 3.0 | L. COM3: Isolated RS-422/485 |
| F. 2 x LAN | M. Power Button |
| G. VGA | |

Figure 2.3 Panel PC I/O Ports

2.2 Installation Procedures

The procedures for device installation should be conducted in the following order:

1. Install SATA HDD or mSATA storage
2. Install a memory card
3. Install peripheral devices
4. Mount the panel PC
5. Configure the system

2.2.1 HDD Installation

Install a SATA HDD or mSATA storage

PPC-3100-RE9A

1. Unscrew the eight retention screws and remove the rear cover.

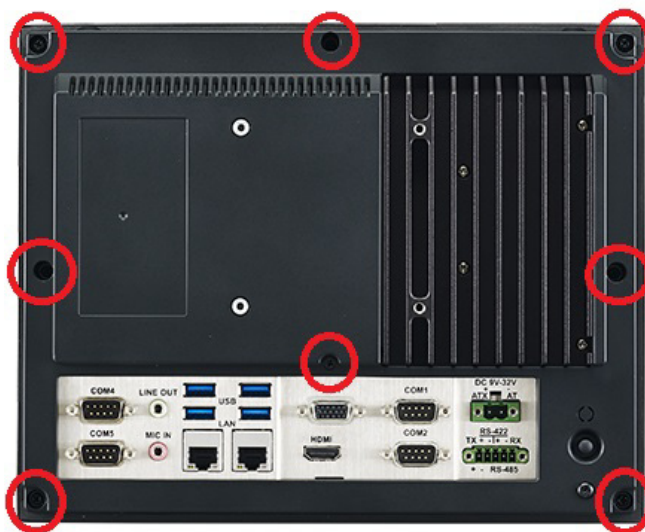

2. Unscrew the six retention screws and remove the HDD cover.

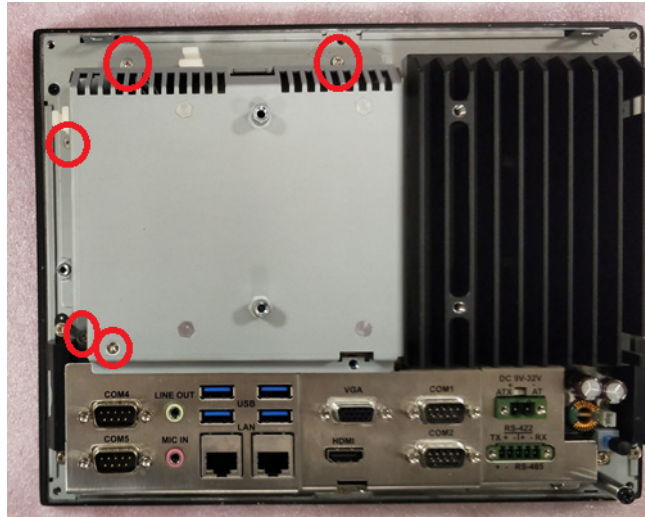

3. Unscrew the four retention screws and remove the HDD bracket.

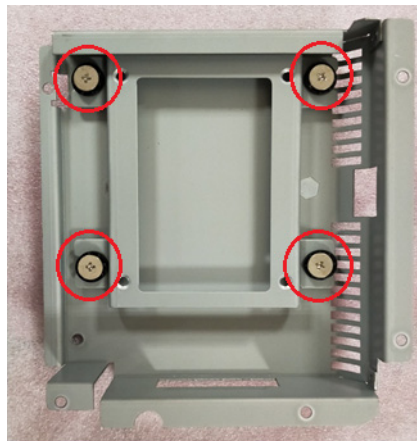

4. Install a SATA HDD and affix it in place using four retention screws.



5. Connect the SATA cable and replace the HDD bracket.



6. Route the SATA cable.



7. Connect the SATA cable to the motherboard.



8. Replace the HDD cover and affix it in place using five retention screws.

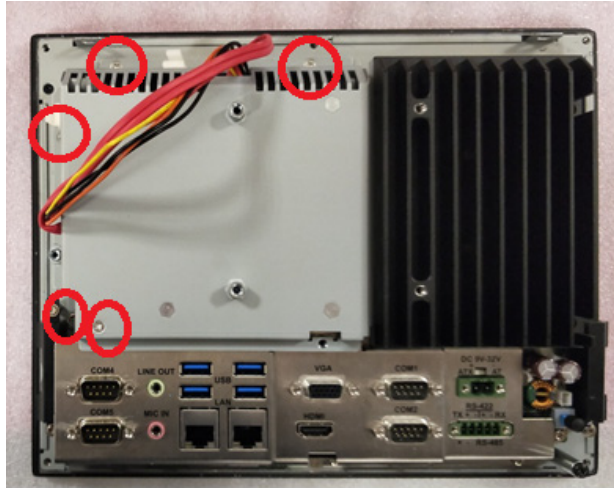

9. Secure the SATA cable with the line buckle and close the rear cover.

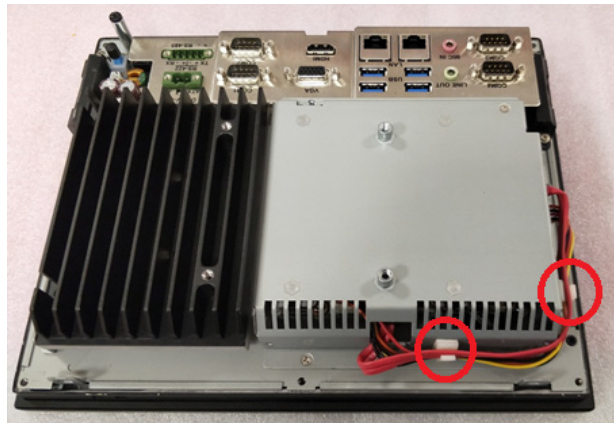

PPC-3120-RE9A

1. Unscrew the eight retention screws and remove the rear cover.

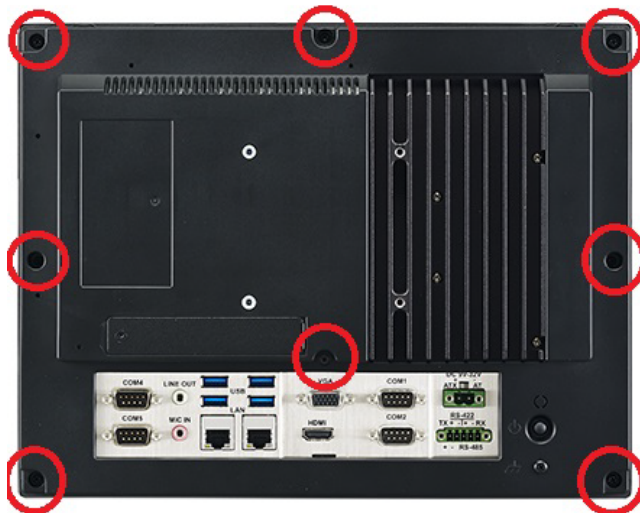

2. Unscrew the six retention screws and remove the HDD cover.

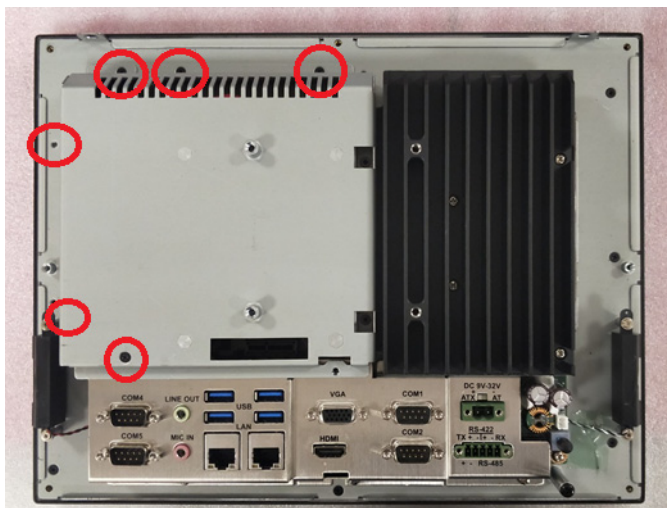

3. Unscrew the four retention screws and remove the HDD bracket.

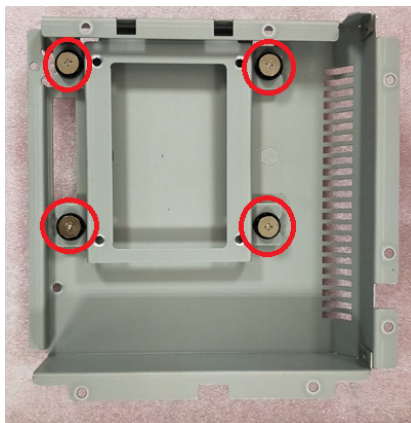

4. Install a SATA HDD and affix in place using four retention screws.



5. Connect the SATA cable and replace the HDD bracket

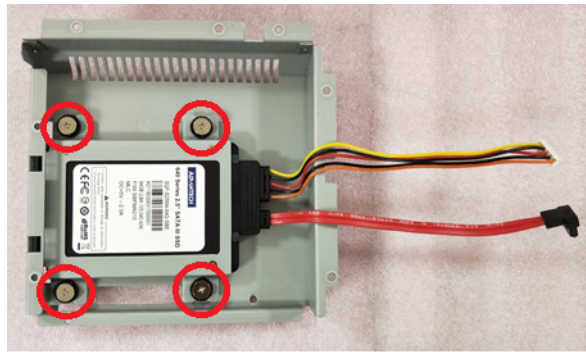

6. Connect the SATA cable to the motherboard and replace the HDD cover.



2.2.2 mSATA Installation

1. Insert the mSATA card into the socket. Secure the mSATA card in place using the two retention screws provided in the accessory box.

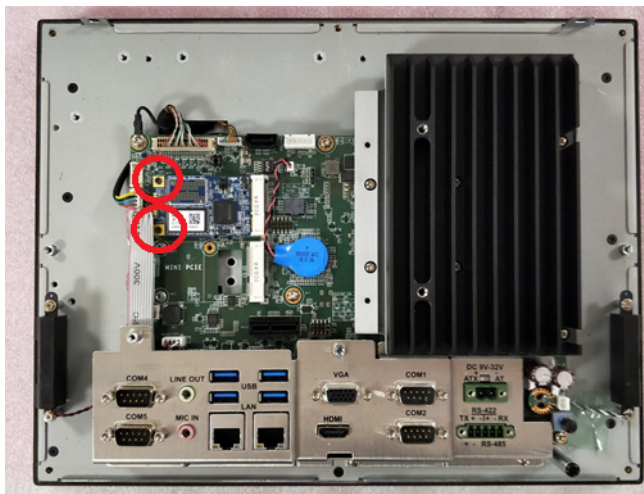

2.2.3 Memory Card Installation

1. Remove the rear cover and HDD cover. Then unscrew the six retention screws to open the heatsink.

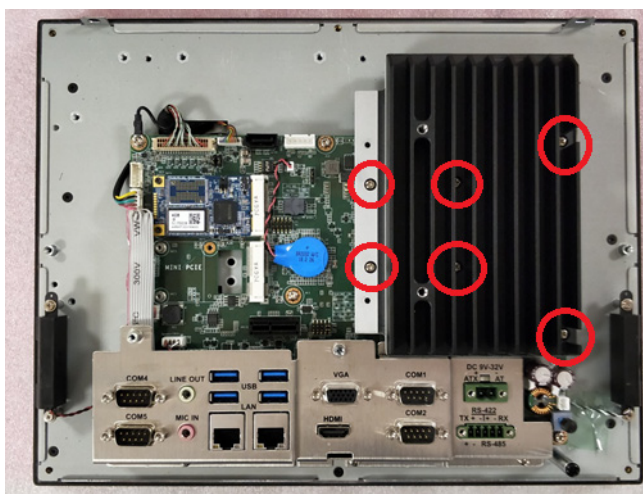

2. Insert the memory card into the slot highlighted in red in the image below. Next, install the thermal pads for the memory card and CPU provided in the accessory box.

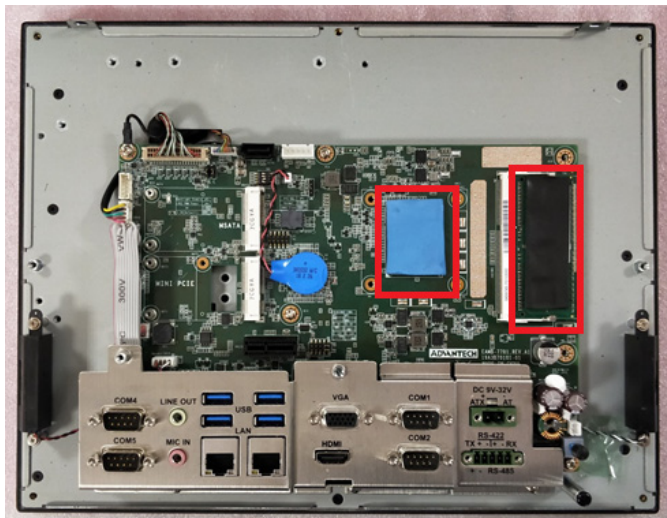
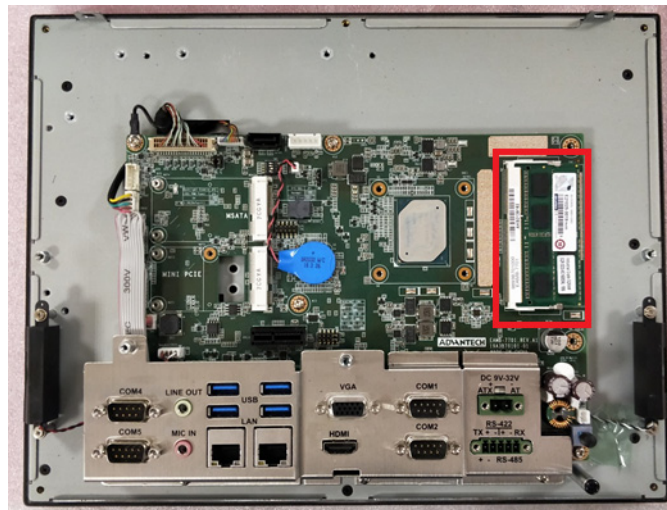

2.2.4 Wireless LAN Module Installation

2.2.4.1 Full-Size Mini PCIe Card Installation

1. Insert a full-size mini PCIe card into the socket. Secure the card in place using the two retention screws provided in the accessory box (the red circles in the image below indicate the locations for the screws).

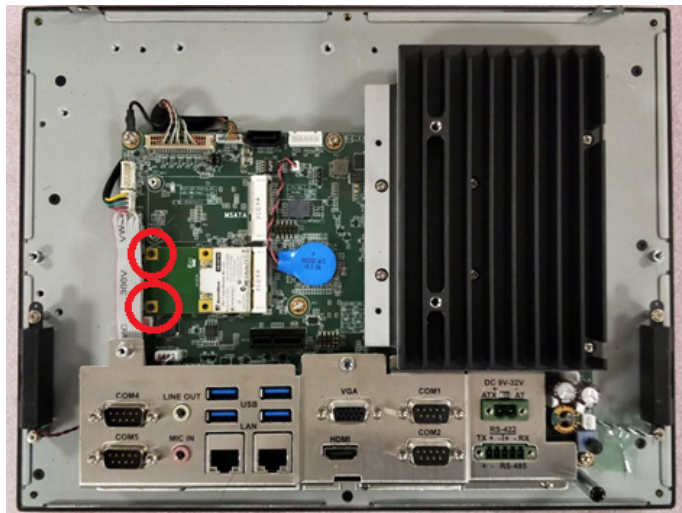

2.2.4.2 Half-Size Mini PCIe Card Installation

1. Insert a half-size mini PCIe card into the socket at an angle. Retrieve the hexagonal screw provided in the accessory box. Insert the screw into the notch on the printed circuit board (circled in red in the image below) and tighten it to secure the card in place.

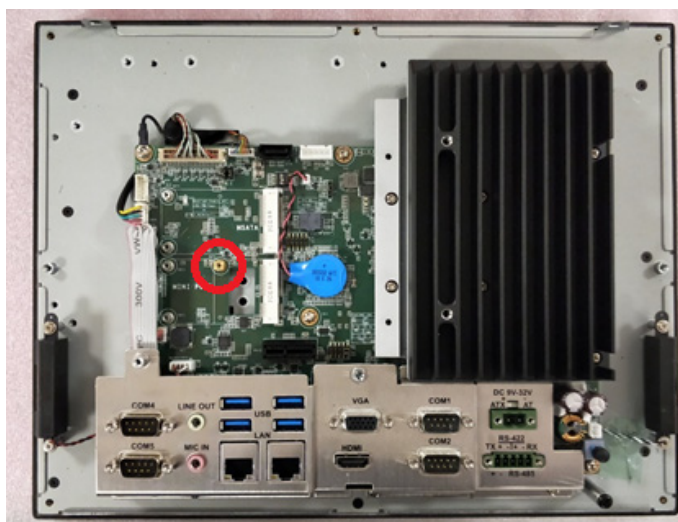

2. Connect the antenna cables and affix them to the brackets. Please note the cable routing shown in the image below.



3. Remove the two plugs at the top of the rear cover.



4. Install the external antennas.



2.2.5 Expansion Kit Installation (for PPC-3120-XE9 only)

1. Remove the block slice and the two retention screws on the rear cover.

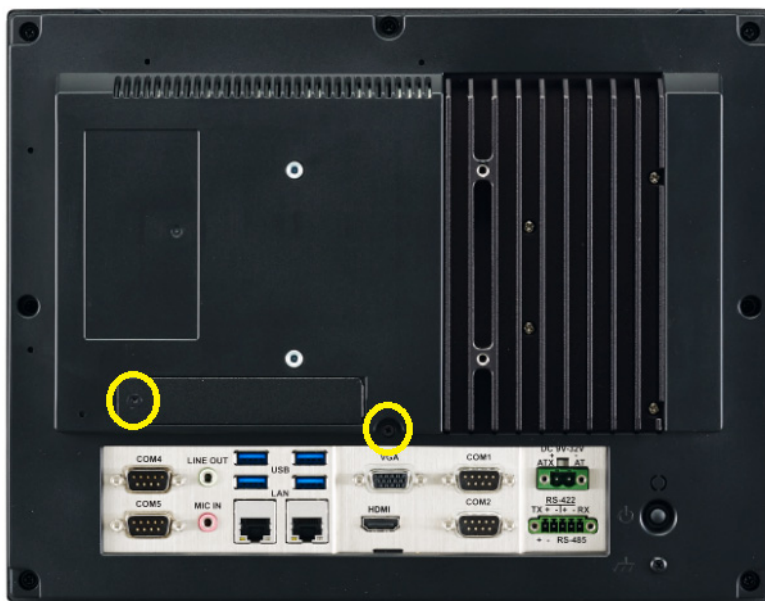

2. Install riser card brackets.

| Item | Screw Specifications | Quantity |
|---------------|---------------------------|----------|
| Yellow circle | T3*8L 1/4R/S D=7 H=2 (2+) | 5 |
| Green circle | M3*8L R/S D=5.5 H=2 (2+) | 1 |
| Blue circle | M4*5L R/S D=7 H=2.6 (2+) | 2 |



3. Select a riser card (PCIe x1 or PCI card) and use two M3 x 5L screws to affix the card in place.

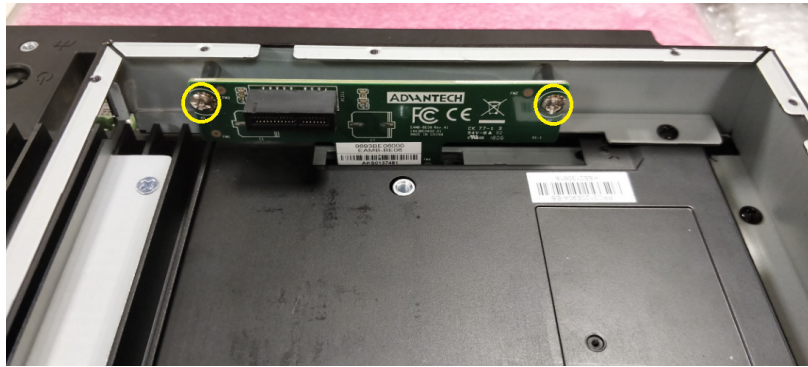

4. Replace the rear cover and affix in place using 11 M3 x 5L screws.

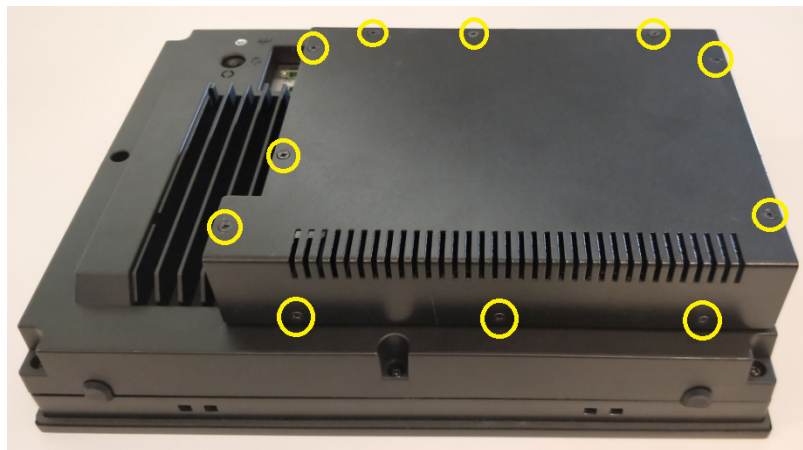

2.3 Mounting the System

Warning! When mounting the panel PC, more than one person should perform the installation to prevent accidental damage to the panel or personal injury.



Le comité constate qu'el-nasr mounting, plus d'une personne installation to prevent the cadre accidental damage or personal injury.

The panel PC supports various mount options, as listed below.

- Wall mounting
- Panel mounting
- Arm mounting
- Stand mounting

2.3.1 Wall Mounting

To mount the panel PC onto a wall, follow the instructions below.

1. Select the location on the wall for the wall mount plate.
2. Mark the locations of the two plate screws holes on the wall.
3. Drill two pilot holes at the marked locations on the wall.
4. Align the wall mount plate screw holes with the pilot holes.
5. Secure the mount plate to the wall by inserting screws into the two pilot holes and tightening them.

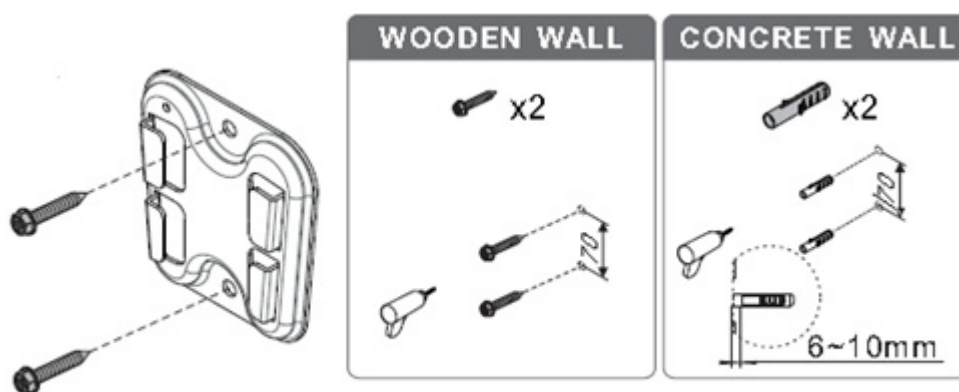

Wall mount plate

6. Insert four M4 screws into the holes on the panel PC and tighten them to secure the bracket to the rear panel.

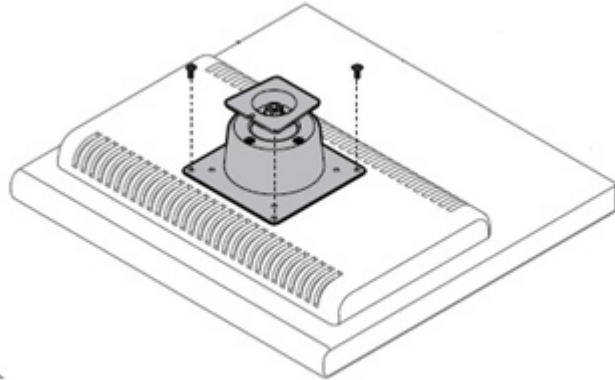

Screw locations on the rear panel

Warning! Ensure that the thread depth of the screws on the rear panel does not exceed 4 mm.



Assurez-vous que la profondeur du filetage des vis sur le panneau arrière ne dépasse pas 4 mm.

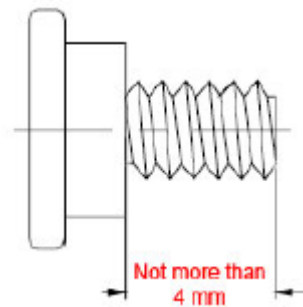

7. To mount the panel PC on a wall, align the wall mount bracket attached to the panel PC with the wall mount plate on the wall and slide the panel PC downwards to hang the bracket on the mount plate, as shown below.

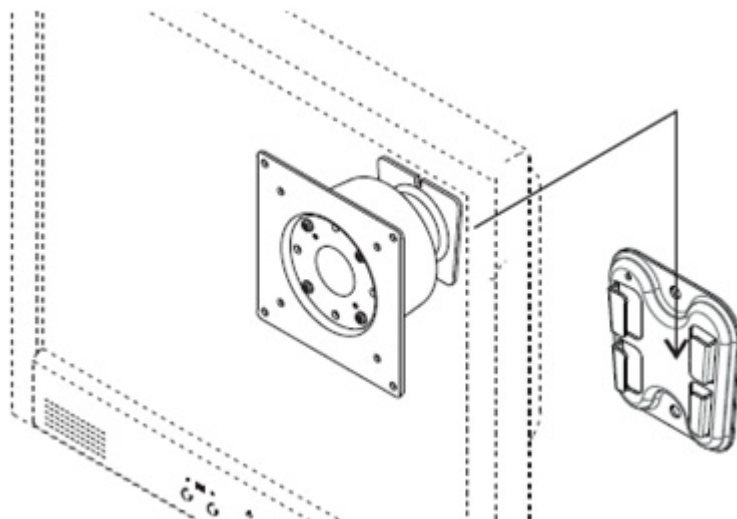

Mounting the panel PC on a wall

8. Secure the panel PC in place by tightening the screws in the wall mount bracket.

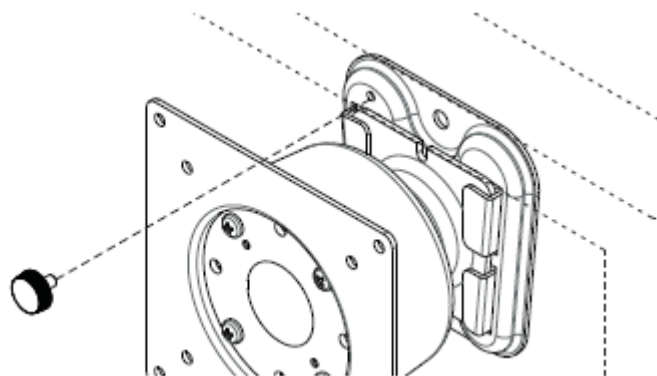

Securing the panel PC

2.3.2 Panel Mounting

To mount the flat bezel panel PC into a panel, follow the steps below.

1. Prepare a panel cutout according to the panel PC dimensions.
For PPC-3100: 265 x 210 mm (10.43 x 8.26 in)
For PPC-3120: 311 x 240 mm (12.24 x 9.44 in)
2. Install the panel PC in the cabinet and retrieve the eight hook brackets provided in the accessory box.

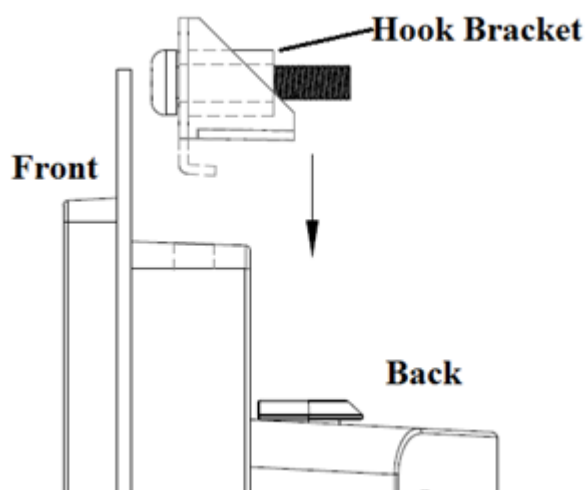

Hook brackets for panel mounting

3. Insert the hook brackets into the holes in the direction of the arrows shown in the image below.

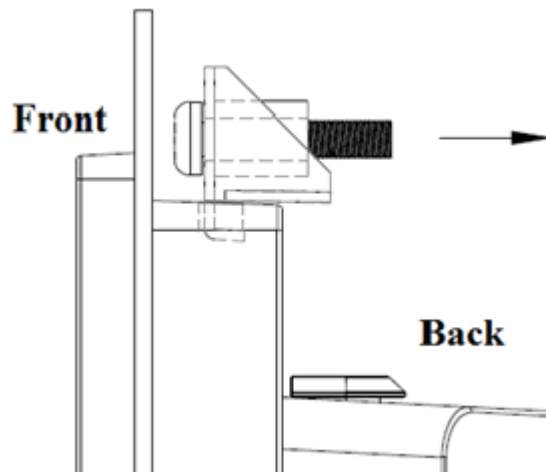

Hook bracket location

4. Tighten the screws to affix the panel PC in place.

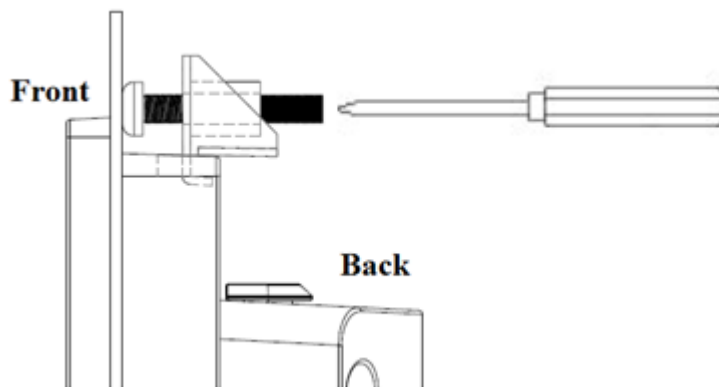

Fasten the hook bracket

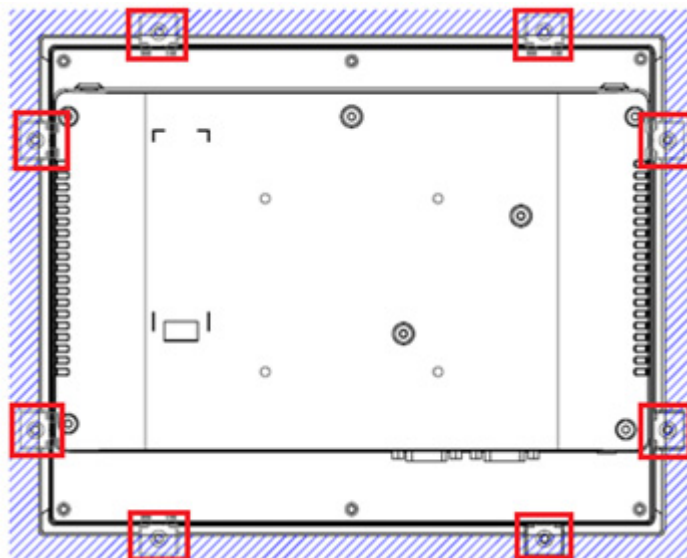

Panel mount rear view

2.3.3 Arm Mounting

PPC-3100/3120-RE9A can be mounted on a VESA-compliant arm mount with a 100 mm interface pad. To affix the panel PC to an arm mount, follow the steps below.

1. Refer to the installation instructions for the mounting arm to correctly mount the arm onto a surface as a base.
2. Align the retention screw holes on the mounting arm interface with the VESA holes of the panel PC. Affix the panel PC to the mounting arm interface using the four M4 retention screws provided in the accessory box.



Arm mount for panel PC

Warning! *Ensure that the thread depth of the screws on the rear panel does not exceed 4 mm.*



Assurez-vous que la profondeur du filetage des vis sur le panneau arrière ne dépasse pas 4 mm.

2.3.4 Stand Mounting

Before installing the stand mount, check that the following items are included with the product:

| Packing List | | | | | | | |
|--------------|---------------|-------------------|------|-----|---------------|------------------|------|
| No. | Name | Qty. | Pic. | No. | Name | Qty. | Pic. |
| A | Screw (M4x8L) | 12 (4 x spare) | | B | Screw (M4x6L) | 6 (2 x spare) | |
| C | Screw (M4x5L) | 2 (1 x spare) | | 1 | Hinge | 1 | |
| 2 | VESA Bracket | 1 | | 3 | Hinge Cover | 1 | |
| 4 | Base Plate | 1 | | | | | |

To mount the panel PC onto a stand, follow the steps below.

1. Use four M4 x 8L screws to affix the VESA bracket to the panel PC. Users can choose between a 75 x 75 mm or 100 x 100 mm VESA mount according to their requirements.

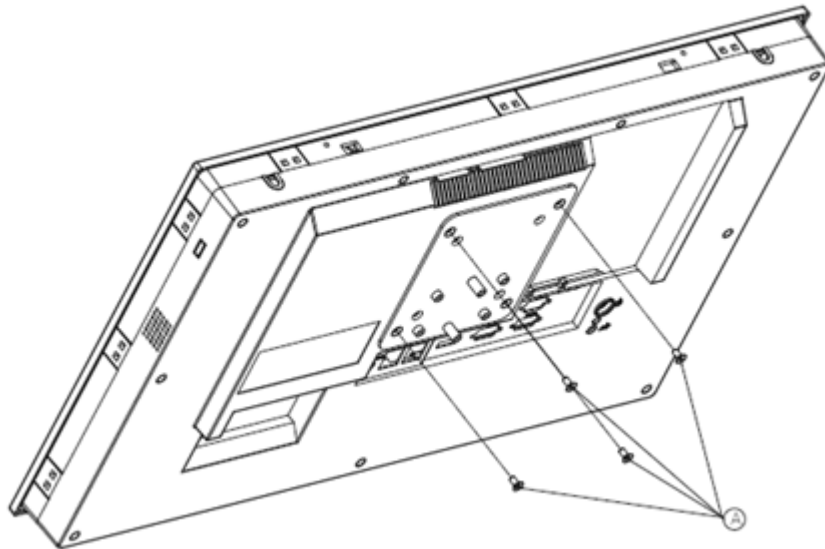

VESA mount screw holes

2. Use four M4 x 8L screws to secure the base plate to the mount stand.

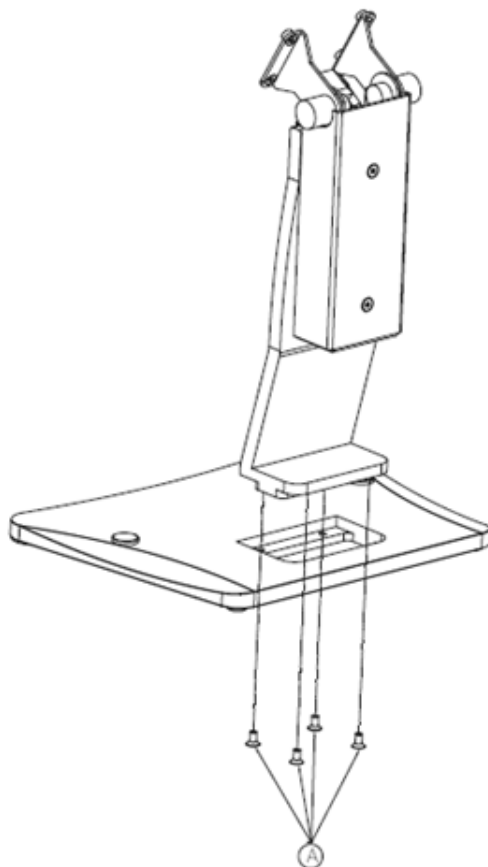

Securing the VESA mount base

3. Use four M4 x 6L screws to secure the mount stand to the VESA mount bracket.

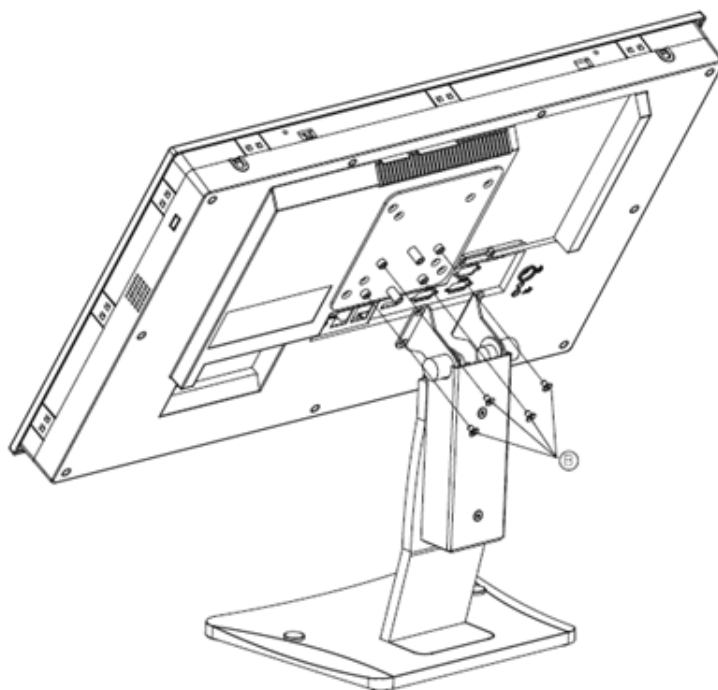

Securing the VESA mount bracket

4. Use one M4 x 5L screw to secure the stand mount hinge cover.

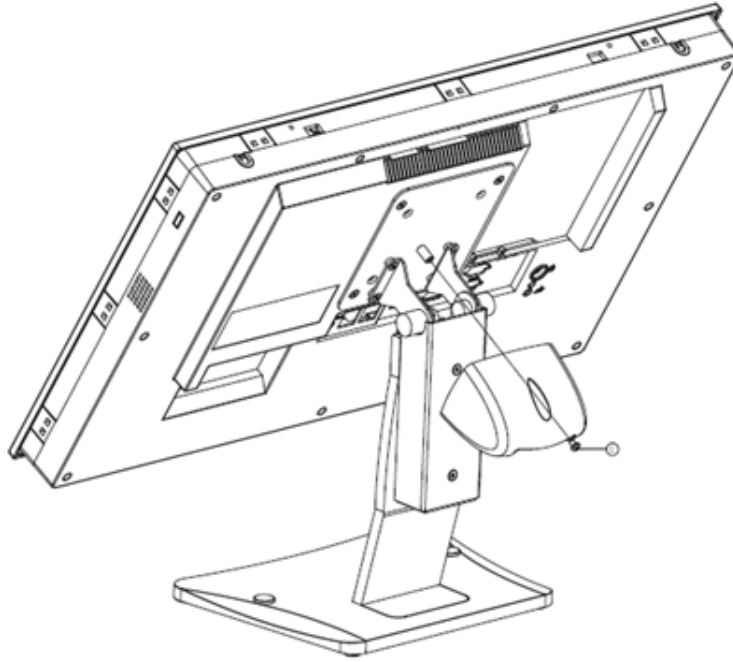

Securing the stand mount hinge cover

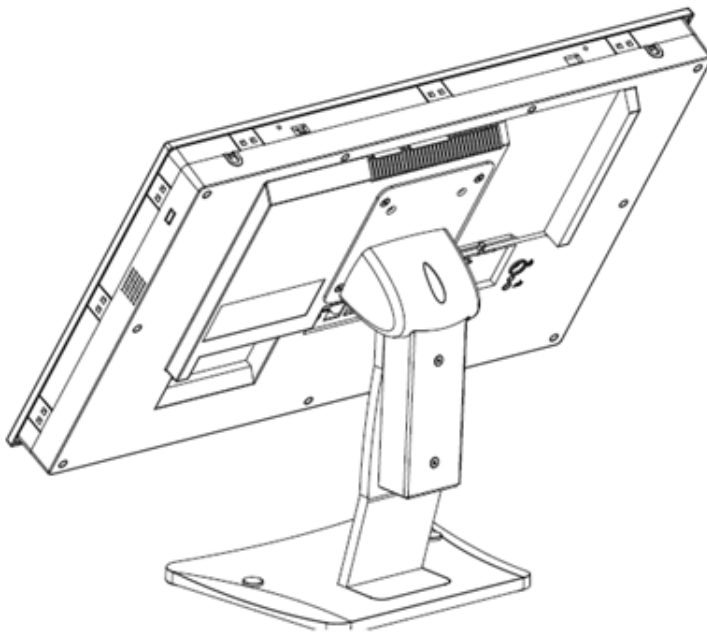

Completed stand mount

Chapter 3

Jumper Settings

- Motherboard Layout
- Jumpers and Connectors
- External COM Ports Pin Definition

3.1 Motherboard Layout

The layout of the motherboard, including the internal peripheral connectors, is shown below. The internal peripheral connectors are accessible when the motherboard is outside of the chassis.

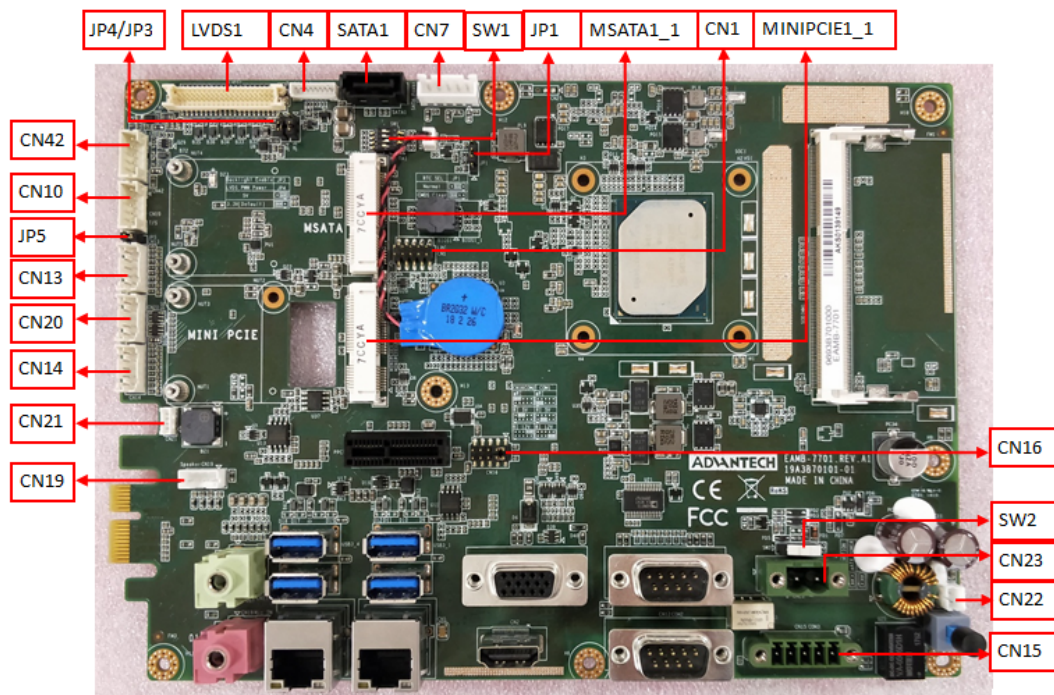

Motherboard layout diagram

| Connectors | Functions |
|------------|--|
| CN1 | LPC Conn. |
| CN4 | LCD Backlight |
| CN7 | SATA Power |
| CN13 | COM4 |
| CN14 | COM5 |
| CN15 | RS422/485 |
| CN16 | COM1/COM2 Ring |
| CN19 | Speaker |
| CN20 | GPIO |
| CN21 | Front LED |
| CN22 | Power Button |
| CN23 | Power input |
| CN42 | Internal USB |
| SW1 | Panel Resolution |
| SW2 | ATX/AT select |
| MSATA1_1 | Mini SATA Conn. |
| MINIPCI1_1 | Mini PCIE Conn. |
| LVDS1 | LVDS Conn. |
| SATA1 | SATA Conn. |
| JP1 | RTC Select |
| JP3/JP4 | Backlight Enable Power Select/PWM Power Select |
| JP5 | Touch Power Select |

3.2 Jumper and Connector Settings

| JP3 | Icon | RTC Select | |
|-------|------|------------|---------|
| (2-3) | P1 | Normal | Default |
| (3-4) | P2 | Clear CMOS | |

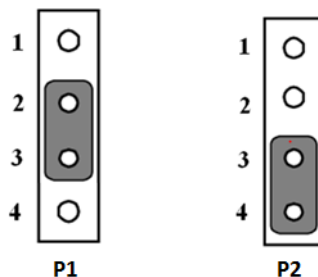

| JP3 | Icon | Backlight Enable Power Select | |
|-------|------|-------------------------------|---------|
| (1-2) | P3 | 5V | Default |
| (2-3) | P4 | 3.3V | |

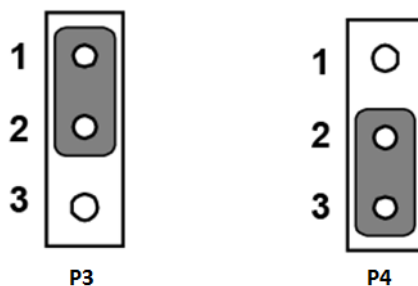

| JP4 | Icon | Backlight PWM Power Select | |
|-------|------|----------------------------|---------|
| (1-2) | P5 | 5V | Default |
| (2-3) | P6 | 3.3V | |

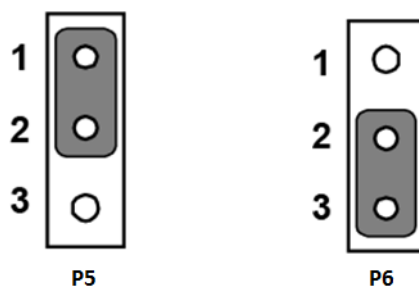

| JP5 | Icon | Touch Power Select | |
|-------|------|--------------------|---------|
| (1-2) | P7 | 3.3VSB | Default |

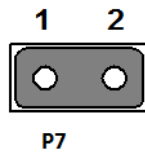

| CN16 | COM1/COM2 RING Type Select | | |
|--------------|----------------------------|---------------|---------|
| (1-3)/(2-4) | P8 | COM1/COM2 RI | Default |
| (3-5)/(4-6) | P9 | COM1/COM2 5V | |
| (7-9)/(8-10) | P10 | COM1/COM2 12V | |

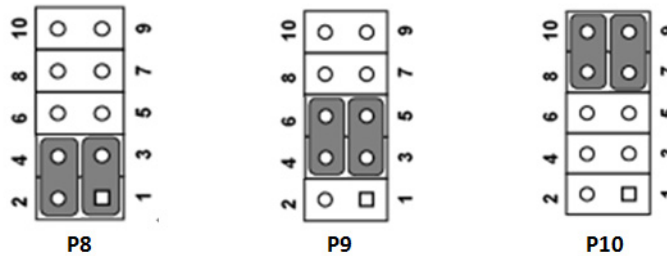

| SW2 | Icon | AT/ATX Select | |
|-----|------|---------------|---------|
| 1-3 | P11 | ATX Power | Default |
| 2-3 | P12 | AT Power | |

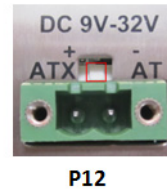
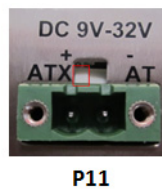

| SW1 | Icon | Panel Resolution | |
|-----------------|------|--------------------|---------|
| 1,2,3,4 ON | P13 | 800x600 (24 bits) | Default |
| 1 OFF; 2,3,4 ON | P14 | 1024x768 (24 bits) | |

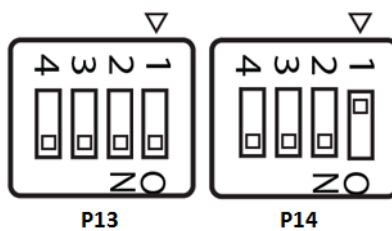

3.3 External COM Ports Pin Definition

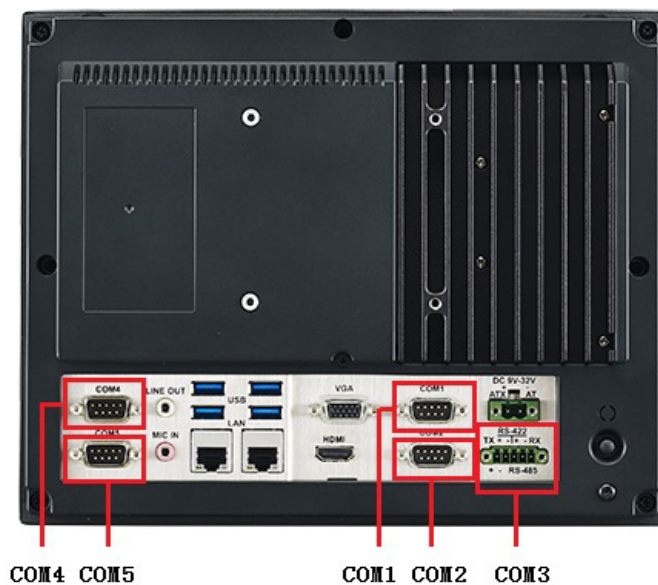

3.3.1 COM1 ~ COM5: RS232

COM1 and COM2 are configured to RI signals as a default. However, they can be set to 5V/12V output via a jumper (CN16).

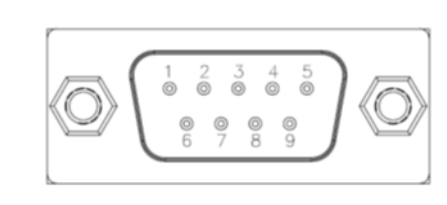

| Pin | COM1/COM2 | COM3/COM4 |
|-----|-----------------------|-----------|
| 1 | DCD | DCD |
| 2 | RXD | RXD |
| 3 | TXD | TXD |
| 4 | DTR | DTR |
| 5 | GND | GND |
| 6 | DSR | DSR |
| 7 | RTS | RTS |
| 8 | CTS | CTS |
| 9 | RING or 5V/12V output | RING |

3.3.2 COM3: RS-422/485 with Isolation

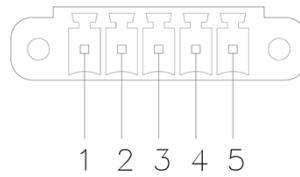

| Pin | 1 | 2 | 3 | 4 | 5 |
|-------|-----|-----|-----|-----|-----|
| RS422 | TX+ | TX- | RX+ | RX- | GND |
| RS485 | D+ | D- | | | GND |

3.3.3 Change COM4 to DIO

To change COM4 to DIO, simple change the cable connection point from CN13 to CN20.

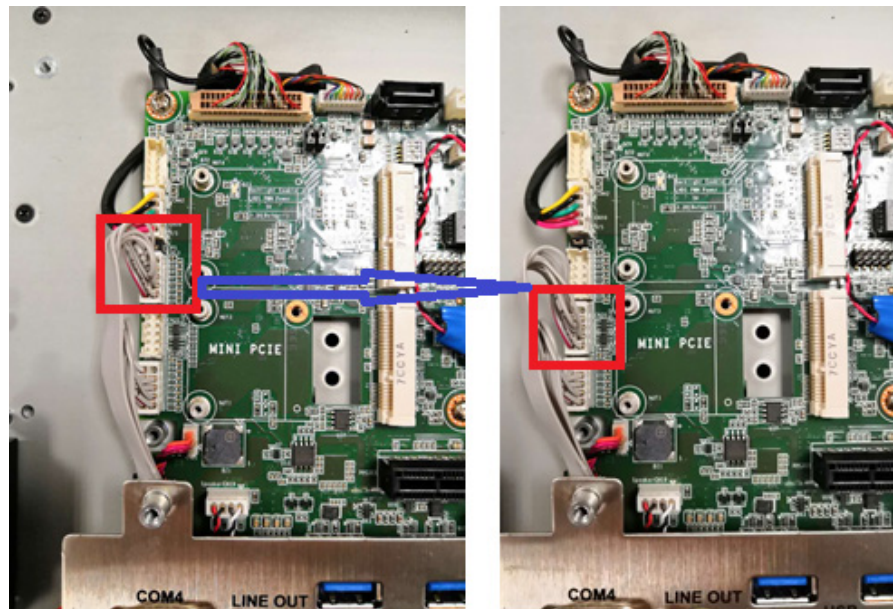

| Pin | COM4 | DIO |
|-----|------|-------|
| 1 | DCD | GND |
| 2 | RXD | GPIO4 |
| 3 | TXD | GPIO0 |
| 4 | DTR | GPIO5 |
| 5 | GND | GPIO1 |
| 6 | DSR | GPIO6 |
| 7 | RTS | GPIO2 |
| 8 | CTS | GPIO7 |
| 9 | RING | GPIO3 |

Chapter 4

Software Setup

- Driver Installation
- BIOS Setup Program

4.1 Driver Installation

Before installing software on the panel PC, install the corresponding drivers to ensure full functionality.

All drivers can be downloaded from the Advantech website

<http://www.advantech.com>

4.2 BIOS Setup Program

4.2.1 Entering BIOS Setup

When the power is turned on, press the button to enter BIOS setup screen. Whenever a change is made, press <F4> to save and exit; otherwise the settings will not be saved in the BIOS.



4.2.2 Adjustment of LCD Brightness

1. Select “North Bridge” in “Chipset” tab.



2. Then select “LCD Control”.

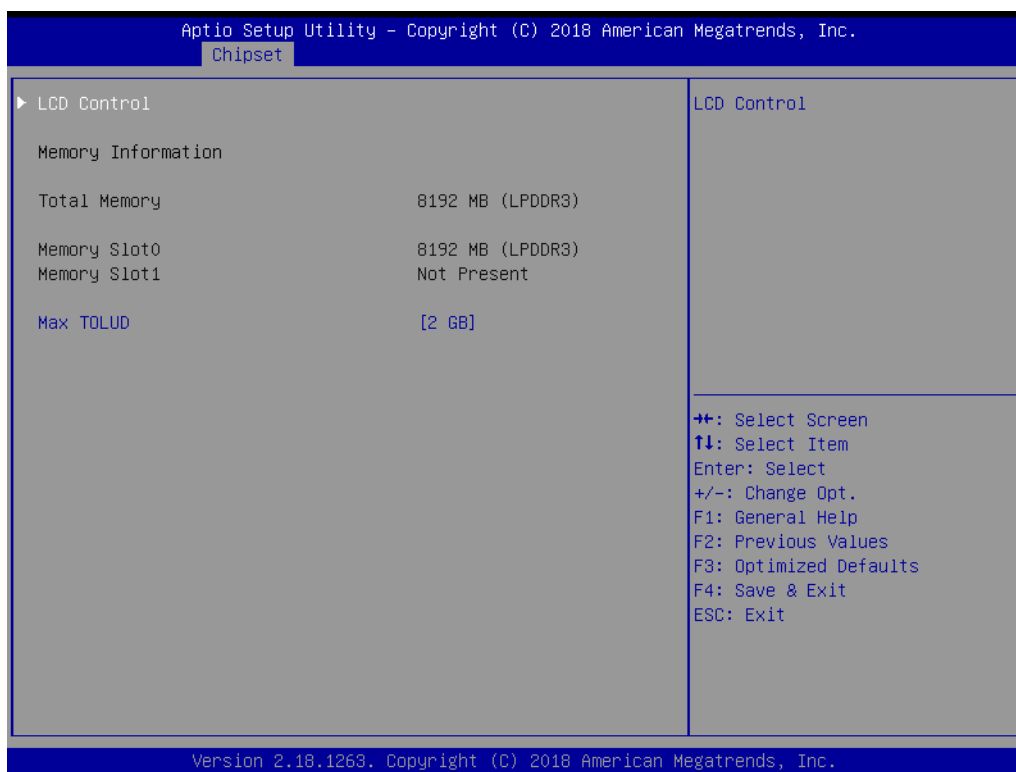

3. Select "Brightness Mode Control".

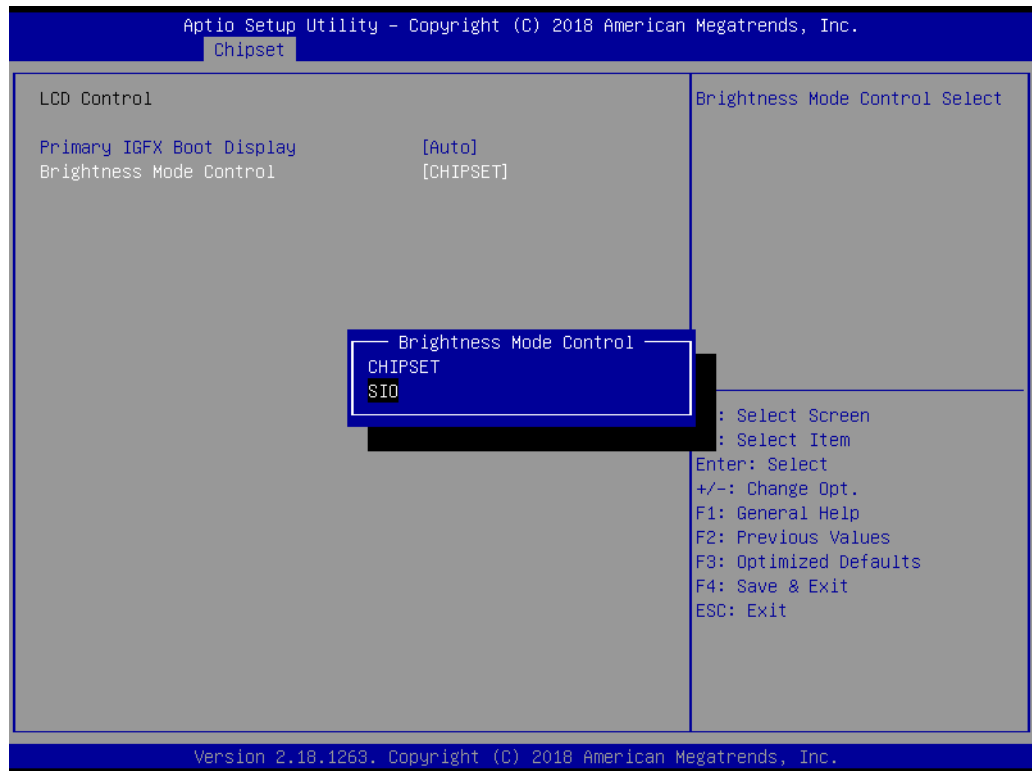

4. There are six brightness levels to choose from in the "Brightness Control" menu.

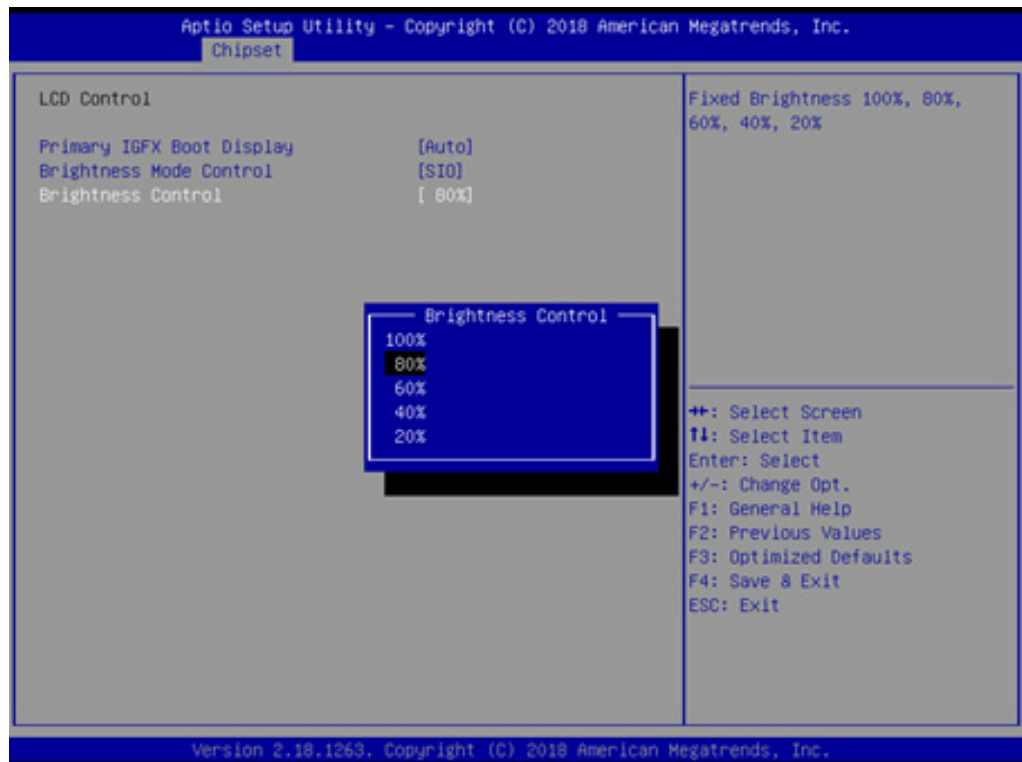

4.2.3 COM2 Mode Selection (RS232/RS422/RS485)

1. Select “NCT6116D Super IO Configuration” in the “Advanced” tab.

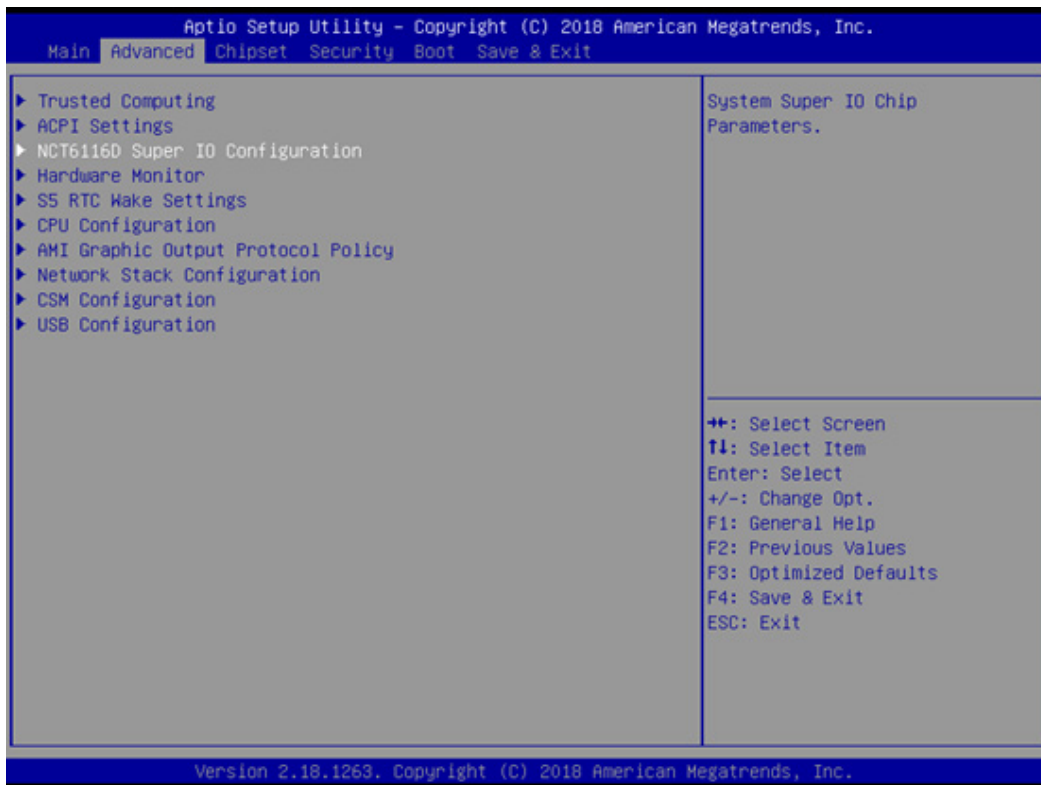

2. Select the “Serial Port 3 Configuration” option.

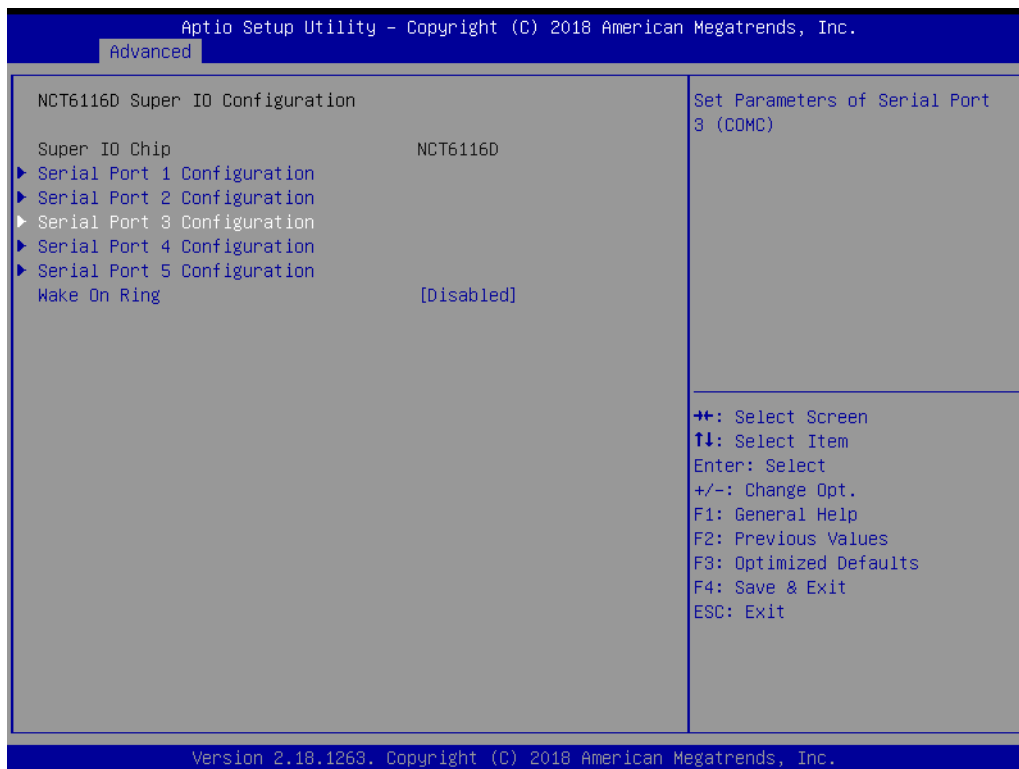

3. Select “Serial Port 3 Mode” and double click to set the COM3 operation mode to RS422 or RS485.

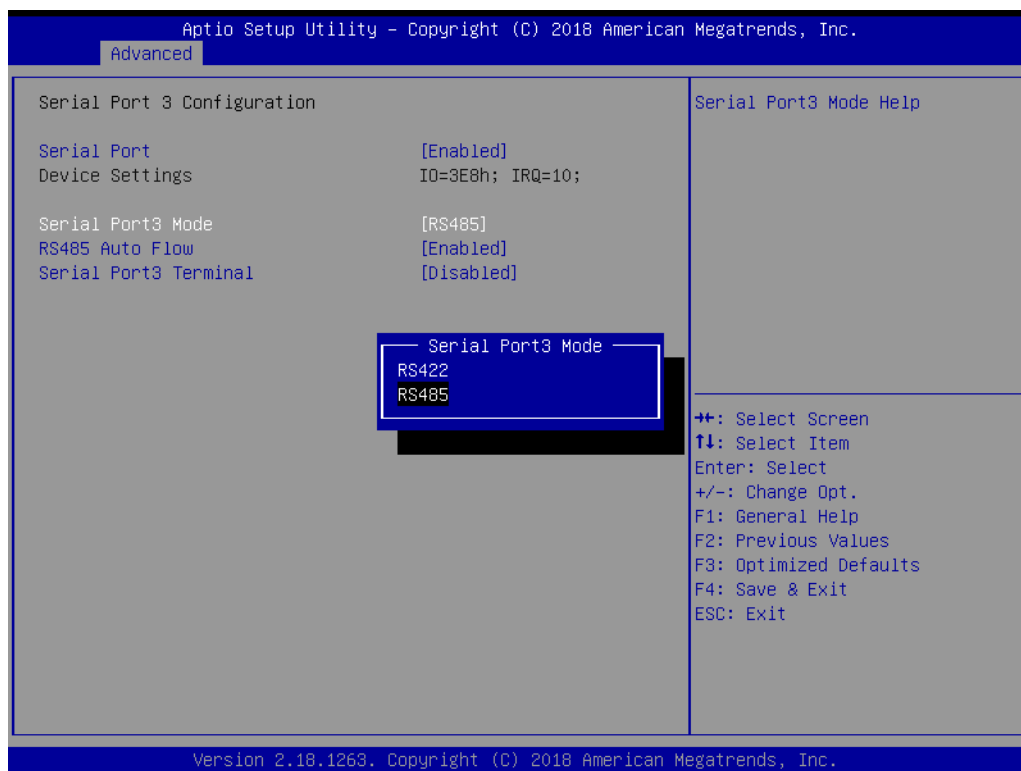

4. When the COM3 mode is set to RS485, the “RS485 Auto Flow” function can be Enabled/Disabled.

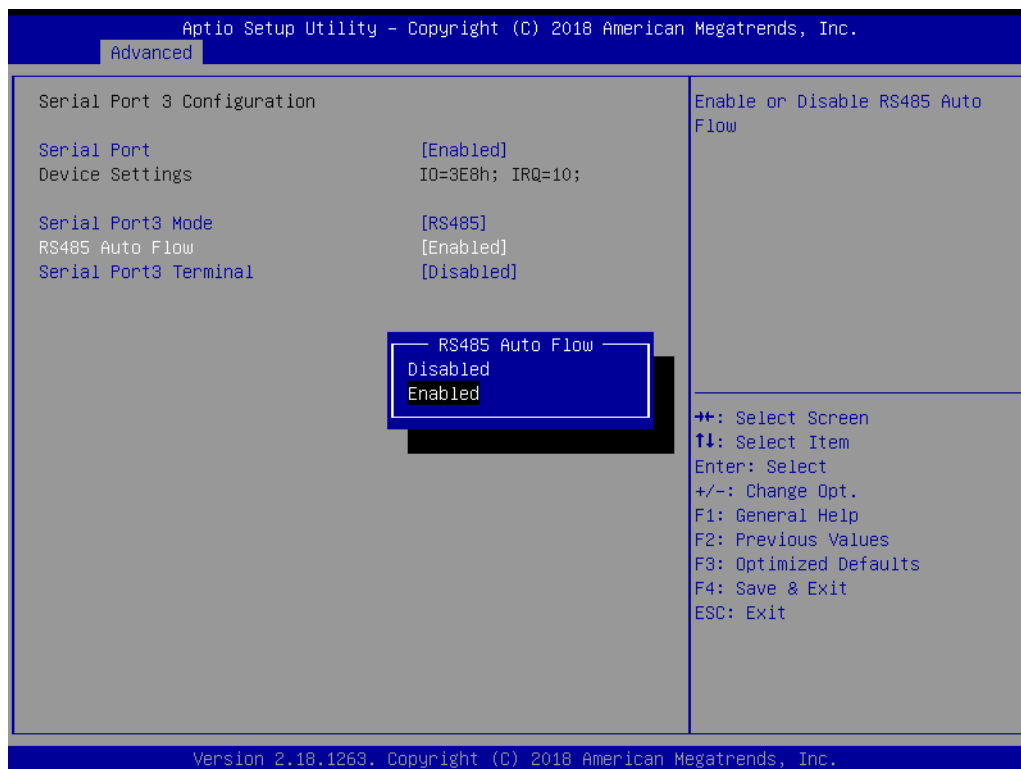

- When the COM3 mode is set to RS485, the “Serial Port3 Terminal” can be Enabled/Disabled.

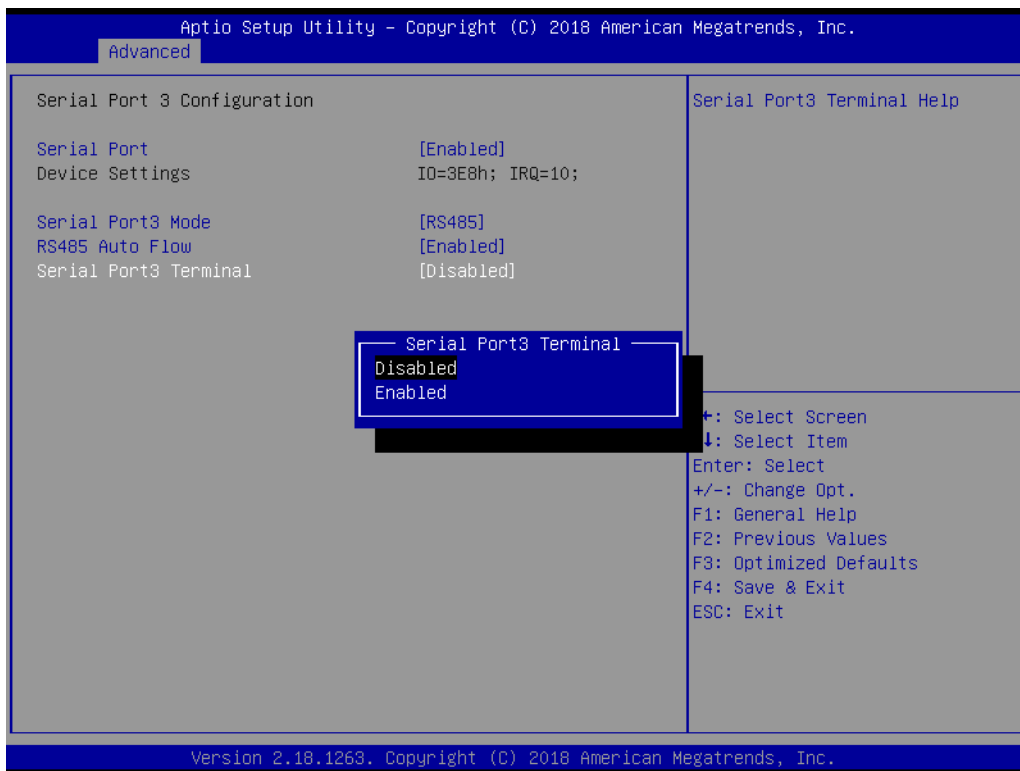

4.2.4 OS Selection

- Select “South Bridge” in the “Chipset” tab.

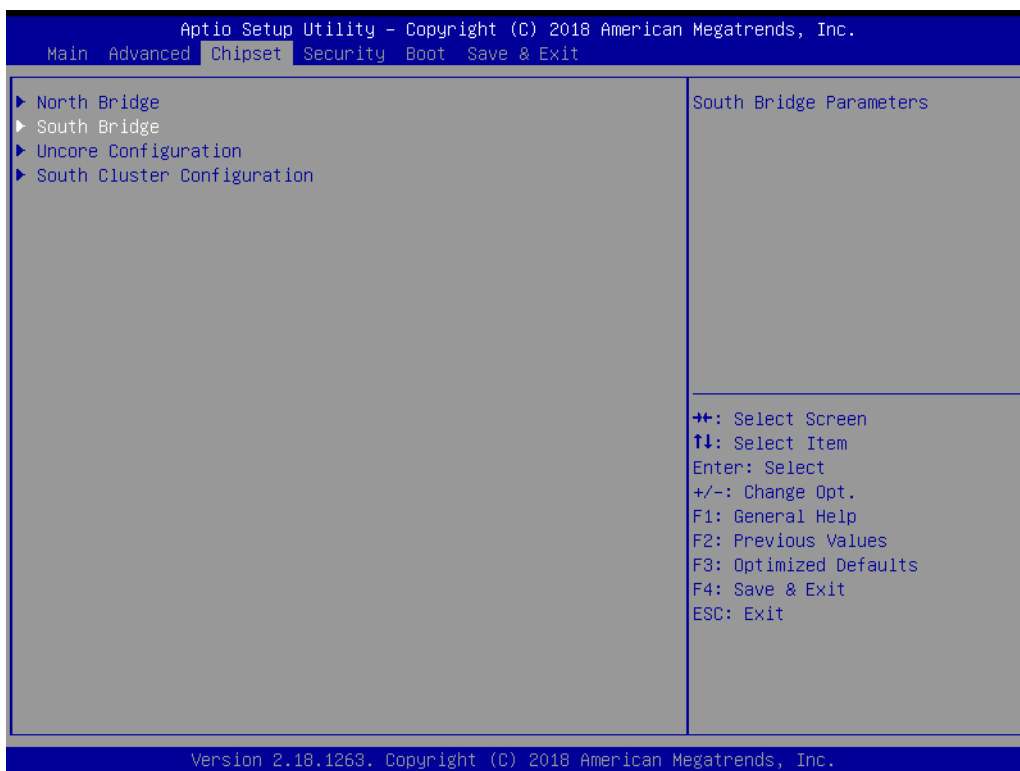

2. The “OS Selection” option allows user to select between Windows, Android, and Linux OS.

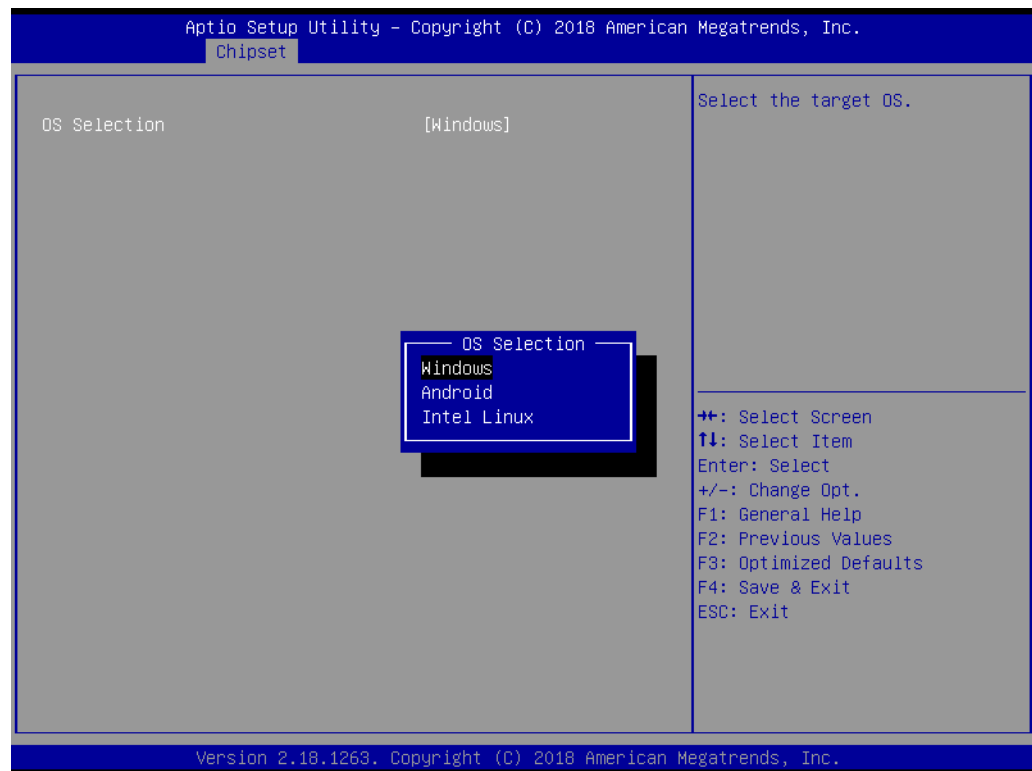

4.2.5 BIOS AT and ATX Setup

1. Select “South Cluster Configuration” in the “Chipset” tab.

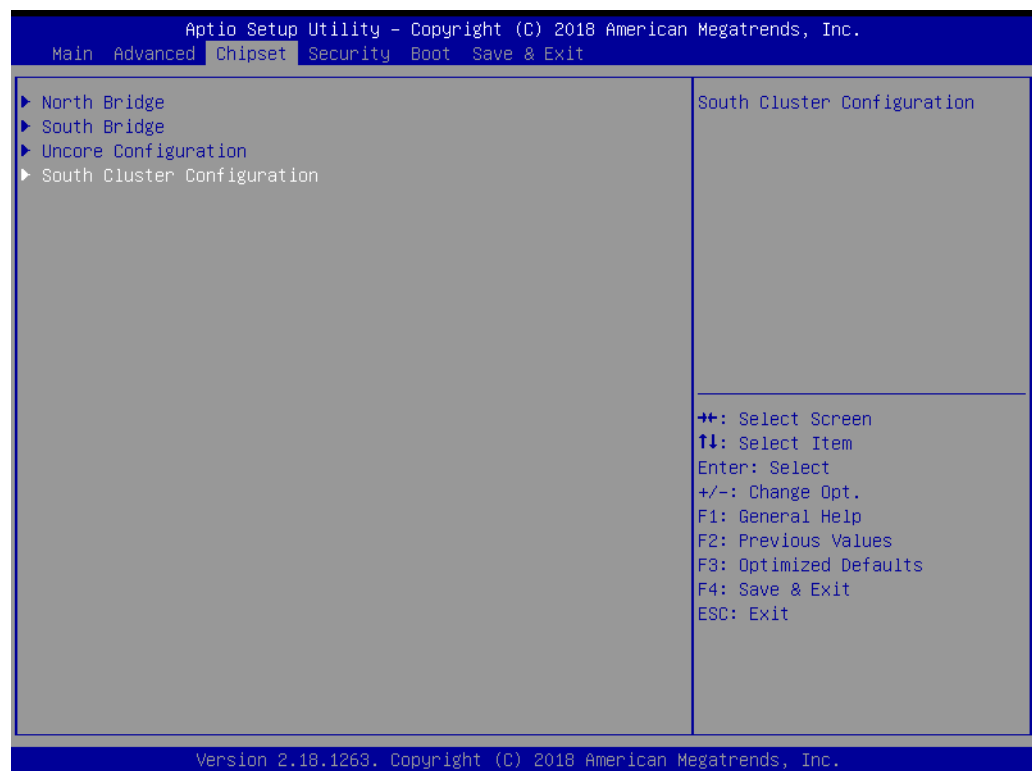

2. Select the “Miscellaneous Configuration” option.

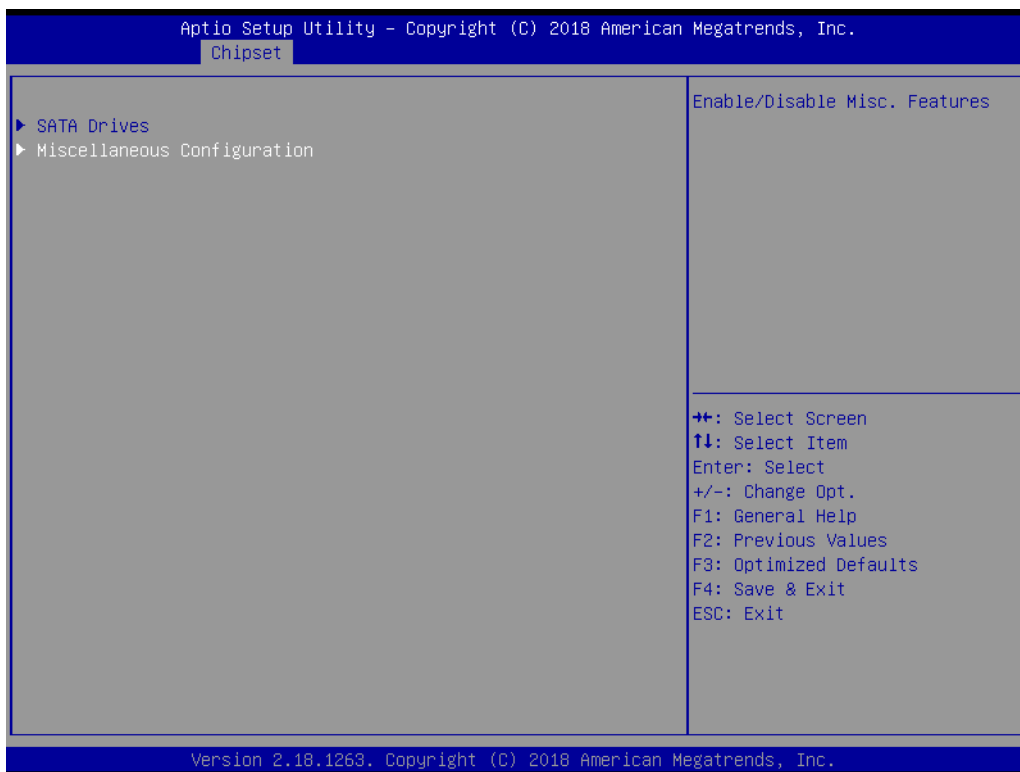

3. In “Restore AC Power Loss”, set the AT Mode as “Power On” and the ATX Mode as “Power Off”.

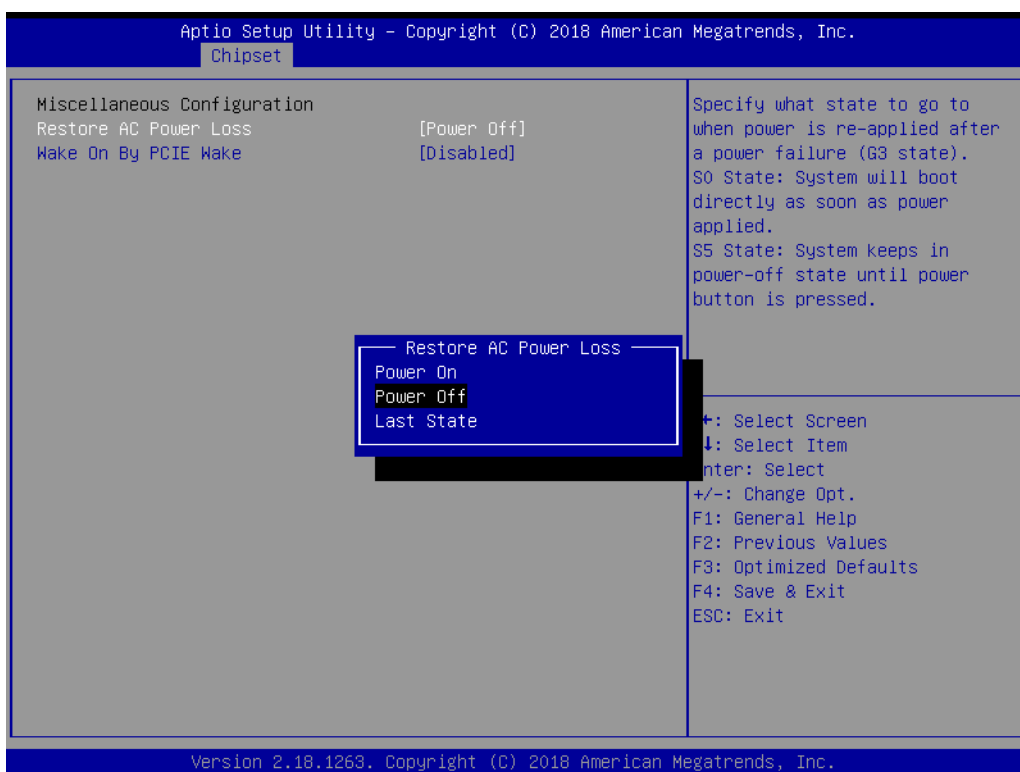

4.2.6 Wake-on-LAN

1. Select “South Cluster Configuration” in the “Chipset” tab.



2. Select the “Miscellaneous Configuration” option.

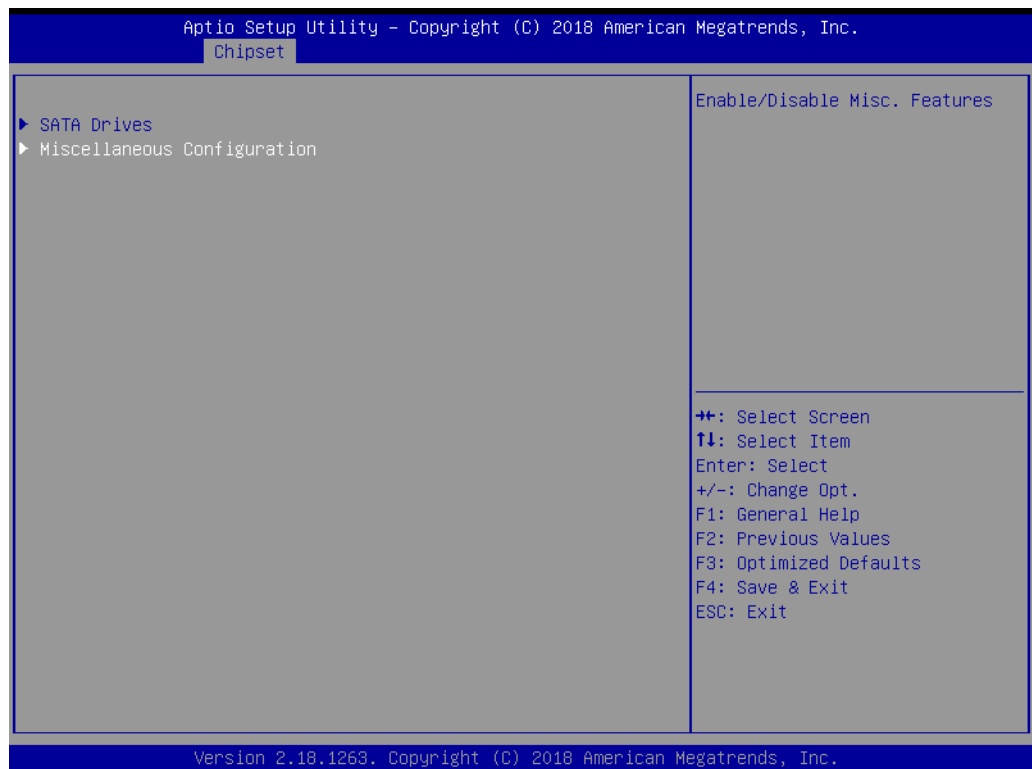

3. Set "Wake-By-PCIE" option to Enabled.

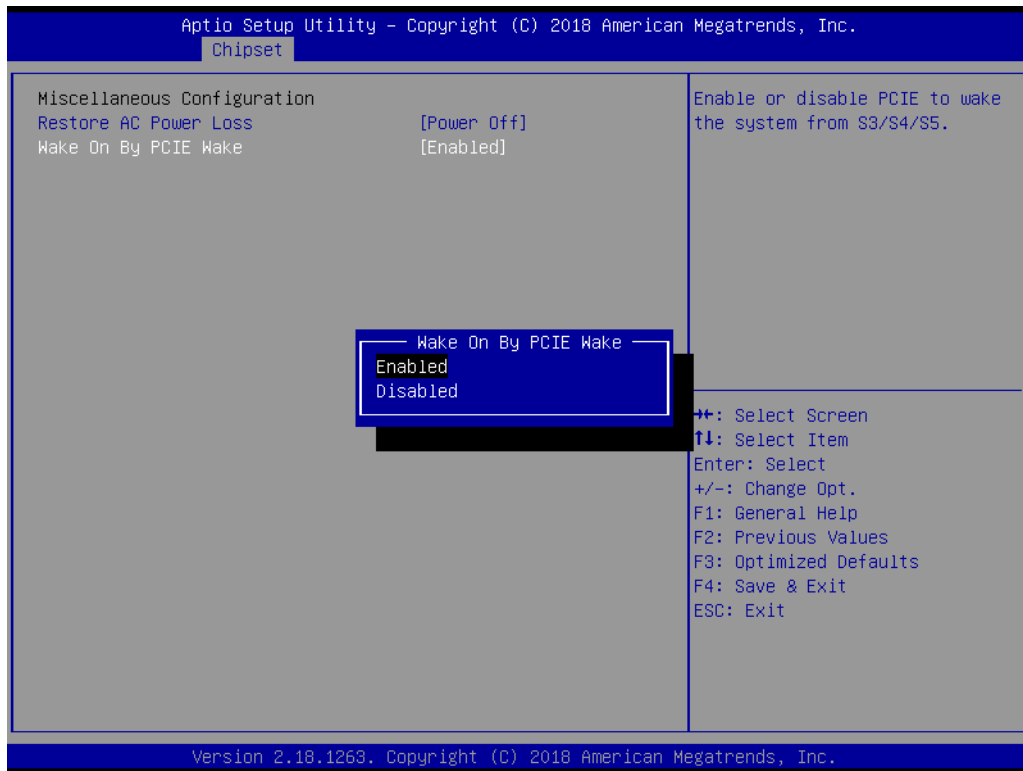

Appendix **A**

Watchdog Timer Programming

A.1 Watchdog Timer Programming Example

The watchdog timer is provided to ensure that standalone systems can always recover from catastrophic CPU failures and crashes. Such events may have been caused by external EMI or a software bug. If the CPU is malfunctioning, the watchdog timer performs a hardware reset to return the system to a previous state.

The following watchdog timer example code is written in Intel 8086 assembly language for a DOS environment. The number of watchdog timer intervals can be set as 0 ~ 255 via software.

```
-----  
; Enter the Extended Function Mode  
;-----  
MOV DX, 2EH; dependency by HW strap to 2Eh  
MOV AL, 87H  
OUT DX, AL  
OUT DX, AL  
  
;-----  
; Configure logical device 8, configuration register CR30  
;-----  
MOV DX, 2EH  
MOV AL, 07H  
OUT DX, AL; point to logical device number reg.  
MOV DX, 2FH  
MOV AL, 08H  
OUT DX, AL; select logical device 8  
  
;-----  
;Set WDT logic device to active  
;-----  
MOV DX, 2EH  
MOV AL, 30H  
OUT DX, AL; select CR30  
MOV DX, 2FH  
MOV AL, 01H  
OUT DX, AL; set WDT active  
  
;-----  
;Initial WDT mode  
;-----  
MOV DX, 2EH  
MOV AL, F0H  
OUT DX, AL  
MOV DX, 2FH  
MOV AL, 00H; bit 0: 0 = pulse mode, 1 = level mode; bit 3: 0 = second mode, 1 =  
minute mode  
OUT DX, AL; set second mode, default value
```

```
;-----  
;Set WDT timeout value  
;-----  
MOV DX, 2EH  
MOV AL, F1H  
OUT DX, AL  
MOV DX, 2FH  
MOV AL, 05H  
OUT DX, AL; set timeout value as 5s; 00 = timeout disabled  
  
;-----  
;Exit the extended function mode  
;-----  
MOV DX, 2EH  
MOV AL, AAH  
OUT DX, AL
```

www.advantech.com

Please verify specifications before quoting. This guide is intended for reference purposes only.

All product specifications are subject to change without notice.

No part of this publication may be reproduced in any form or by any means, such as electronically, by photocopying, recording, or otherwise, without prior written permission from the publisher.

All brand and product names are trademarks or registered trademarks of their respective companies.

© Advantech Co., Ltd. 2019